

LAVINA®



LAVINA® 25G-S User Manual



Tech Support Line: 800-987-8403 | www.superabrasive.com | info@superabrasive.us

CONTENT

1. GENERAL INFORMATION

Preface	3
Manufacturer	3
General Description	3
Machine Characteristics	3
LAVINA® 25G Pro Main Design	3
Technical Data	4
Environmental Conditions	4
Vacuum Connection	4
Label Data	4
Customer service	4

2. SAFETY INSTRUCTIONS

Recommended Use	4
Prohibited Use	4
Preparation for Work	5
Protection Devices	5
Arrest Functions	5
Safe Use	5
Propane Safety	5
Fire Safety	5
Emission	5
Hazard Communication	5
Local Agencies and Regulations	6
Residual Risks	6
Before You Begin	6
Operating the Machine	6
After Work is completed	6
The Work Area	7
Personal Protective Equipment (PPE)	7
Testing	7
Operator	7
Propane Cylinders	7
Refueling Cylinders	8
Storage Cylinders	8
Transporting Cylinders	8

3. HANDLING AND TRANSPORTATION

Adjusting the handle	8
Lift the machine from work to tool mounting position	9
Lifting	9
Storage	9

4. OPERATION

Preliminary Controls	9
Water Flow Control Unit	9
Adjusting and Mounting Tools	9
Control Board	10
Starting the Machine	10
Operating Machine	10
Stopping Machine	10
Alarm	10

5. ACCESSORIES

Weights	11
Tool Holder Key	11
Foam Plate	11
Security Plate for Quickchange Pads	11

6. POPULAR TOOLS AND APPLICATIONS

Tools	12
-------	----

7. EXPLODED VIEW

General Exploded View	13
Top Cover Exploded View 1	13
Planetary Drive Exploded View	13
Top Cover Exploded View 2	13
Bottom Cover Exploded View 1	14
Bottom Cover Exploded View 2	14
Carriage Exploded View	14
Tool Holder Exploded View	14

8. MAINTENANCE AND INSPECTION

Remark	15
Mechanical parts	15
Cleaning	15
Check Hourly	15
Check Daily	15
Check and replace after the first 8 working hours	15
Check and replace after the first 15 working hours	15
Check and replace every 50 Working Hours	15
Check and replace every 200 Working Hours	16
Check and replace every 400 Working Hours	16
Vacuum	16
Water Leaks	16
Mechanical Parts	16
Electrical System	16

9. TROUBLESHOOTING

9.1 Engine	17
9.2 Checking and changing the oil	17
9.3 Separating the head from the carriage	17
9.4 Dismounting/mounting of the engine	18
9.5 Replacing the clutch	19
9.6 Dismounting and Mounting Tool Holders to change Buffers and Spiders, Changing V-Rings and Felt-Rings	19
9.7 Tensioning and Replacing the Planetary Belt	20
9.8 Tensioning Used Planetary Belt	20
9.9 Mounting and Tensioning a new Planetary Belt	21
9.10 Checking the Tensioning of the Belt	21
9.11 Replacing the Pulley Units	22
9.12 Mounting the belt	23

10. WARRANTY AND RETURNS

Warranty	24
Return	24

11. DISPOSAL

	24
--	----

12. MANUFACTURER'S CONTACTS

	24
--	----

13. SPARE PARTS

13.1 General parts	25
13.2 Top Cover 1 parts	25
13.3 Engine Base Parts	26
13.4 Top Cover 2 parts	26
13.5 Planetary Drive Parts	27
13.6 Water Supply parts	27
13.7 Bottom Cover 1 Parts	28
13.8 Tool Holder Parts	28
13.9 Bottom Cover 2 Parts	29
13.10 Control Board Parts	29
13.11 Carriage parts	30
13.12 Engine parts	31

1. GENERAL INFORMATION

This owner's manual is intended for the operator of the Lavina® S machine, the servicing technician as well as for anyone involved with operating or servicing the machine. We recommend that you read the instructions very carefully and follow them strictly. The manual includes information about assembling, using, handling, adjusting and maintaining your Lavina® S floor grinding and polishing machine.

MANUFACTURER

Superabrasive was founded 24 years ago, in 1987, as a manufacturer of high quality diamond tools for the stone and concrete industry. Today, Superabrasive is one of the world's leading companies in the production of diamond tools and floor grinding machinery. At Superabrasive, we strive to deliver the very best solutions to our customers, and enable them to work more efficiently.

GENERAL DESCRIPTION

The Lavina® S machine is intended for grinding, polishing and buffing concrete, marble, granite, limestone and terrazzo surfaces with diamond tools.

The Lavina® S machine is a three-disc machine, which can be used dry as well as wet.

For best results, use only tools manufactured or recommended by Superabrasive and its distributors. Additionally, the machine could be used for grinding wood floor surfaces.

⚠ WARNING The Lavina® S machine is manufactured and fitted for the above-mentioned applications only! Every other use may possess risks to the persons involved.

MACHINE CHARACTERISTICS

The Lavina® S machine is made of two main component sections:

LAVINA® 25G-S MAIN DESIGN

- **The two main components** are the carriage and main head.

The handle on the frame is adjustable in height and allows the operator to work in a correct and safe posture.

- **The halogen spotlight** (Fig.1.2) enables the operator to work in darker areas.

⚠ WARNING Existing lighting system does not replace adequate overhead lighting.

- A **frame (U-joint technology)** on top of the motor base is providing the main head a possible to move to all sides and it gives more grinding capacity.
- **The propane tank** is placed on a tank holder on the backside of the frame.
- **The control panel** (fig.1.3) is positioned on top of the frame and contains switching devices, which ensure the proper functioning of the engine, LPG supply turning on/off of the electromagnetic connector/clutch.
- **The water tank** is on the opposite side of the frame, so that the weight of the water does not affect the operation of the machine. The frame weight, on the other hand, is fully absorbed by the driving wheels. An electric pump sprays the water through a front sprayer or internal
- **The water tank** is on the opposite side of the frame, so that the weight of the water does not affect the operation of the machine. The frame weight, on the other hand, is fully absorbed by the driving wheels. An electric pump sprays the water through a front sprayer or internal
- **The Engine Kawasaki FS481V** with electric clutch is mounted on the base plate and it is driving the three heads with a belt system.
- **The planetary motion** derives from the main engine, driven by a second flat belt,
- **The self-leveling Guard** is designed to have contact with the surface. Anytime, no matter the height of the tool used.
- **"Quickchange" tool holder** is designed to hold the tools with "Quickchange" connection
- **The "Foam" tool holder** is designed to hold tools with Velcro connection. It is mounted on each of the three grinding heads with a key lock (butterfly). The Velcro makes changing of tools fast and easy.

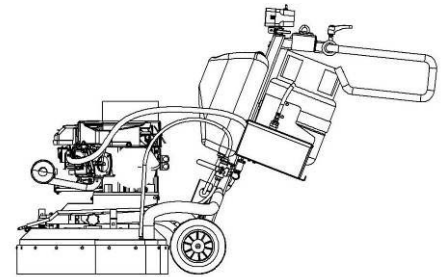

Figure 1.1



Figure 1.2



Figure 1.3

ENVIRONMENTAL CONDITIONS

The temperature range for operating the Lavina® S machine outdoors is between 41°F and 86°F or 5°C and 30°C. Never use the Lavina® S machine during rain or snow when working outdoors. When working indoors, always operate the machine in well-ventilated areas.

VACUUM CONNECTION

A connection for a vacuum dust extractor is located on the carriage. The Lavina® S machine does not include a vacuum dust extractor. The customer must purchase the vacuum dust extractor separately. The hose of the vacuum extractor must be Ø 50.8 mm and can be glided over the pipe. The vacuum dust extractor must be adapted for floor grinders and have a minimum air displacement of 320m³/h with a negative vacuum of 21 kPa.

TECHNICAL DATA

	Lavina® 25G-S	
Engine	Kawasaki FS481V	
Capacity Of Engine	603cc	
Power	13.2 kW/3600 rpm	18 HP/3600 rpm
Tool Holder Rpm	650-1170 rpm	
Engine Rpm	2000-3600 rpm	
Working Width	655 mm	25"
Tool Diameter	3 x 225 mm	3 x 9"
Weight	240 kg	530 lbs
Grinding Pressure	145 kg	320 lbs
Additional Weight	max 2x29 kg	max 2x64 lbs
Application	wet and dry	wet and dry
Vacuum Hose Port	Ø 50,8 mm	2"
Water Tank Capacity	20 l	5.2 gal
Water Feed	with pump (peripheral and front)	
Capacity Propane Tank	9 kg	20 lbs
Machine LxWxH	1930x690x1110 mm	76x27.2x47"
Packing LxWxH Skid	1150x730x1500 mm	45.3x29x59"
Packing LxWxH Crate	1410x730x1100 mm	55.5x28.8x43.3"

VIBRATIONS

The vibrations of the machine are within the limits of directives and harmonized standards from the European Union when the Lavina® S is operated with the recommended tools and in normal conditions.

SONOROUS EMISSIONS

The sonorous emissions are within the limits of directives and harmonized standards from the European Union when the Lavina® S is operated with the recommended tools and in normal conditions. However, as previously stated, the operator must wear ear protectors.

LABEL DATA

The data on the label provides the correct Voltage and kW (needed for operational purposes); Weight (needed for transportation purposes); production year and serial number (needed for maintenance purposes).

CUSTOMER SERVICE

For customer assistance and technical support call your local distributor or call Superabrasive Inc. at 1-800-987-8403 or visit us at: www.superabrasive.com, where you can download a copy of this manual.

2. SAFETY INSTRUCTIONS

RECOMMENDED USE



WARNING

The LAVINA® 25G-S machine is designed and manufactured to grind and polish concrete, terrazzo and natural stone floors. It can be used for renovations as well as for polishing. The machine is designed for dry or wet use. When using it dry, use a vacuum of appropriate size. For more information, please refer to the chapter on handling the vacuum connection.

PROHIBITED USE



WARNING

The machine MUST NOT be used:

- For applications different from the ones stated in the General Description chapter.
- In environments which:
 - Possess risks of explosion

- Possess high concentration of powders or oil substances in the air
- Possess risks of fire
- Feature inclement conditions.
- Possess electromagnetic radiation.
- In nursing homes, hospitals, day-care centers, etc
- In areas where loose tiles or other objects are preventing proper use of the machine.
- In rooms without proper ventilation

- Awareness and basic safety precautions are required when working with propane. As long as these precautions are followed, risk is negligible. Ignorance, however, could pose needless risk.
- The two greatest hazards with propane powered floor care machines are:

- **Carbon Monoxide Poisoning:** This is the most frequently reported incident associated with propane powered floor care machines and is caused by excessive exhaust emissions. The symptoms are headache, dizziness and nausea. A major cause involves engines with poor preventive maintenance practices, usually those with dirty air filters and machines operated in confined areas without adequate ventilation. Another cause may be substandard, inexpensive machines with no emissions control technology and improperly set carburetion.
- **Overfilled Fuel Cylinders:** Nearly all fire related incidents reported result from bringing a cylinder into a building without first checking for overfill. This action is dangerous, unwise, and unnecessary.

PREPARATION FOR WORK

Make sure that:



WARNING

- You have closed the work area, so that no person unfamiliar with operating the machine can enter the area
- The tool plate and tools are mounted on the machine properly
- There are no missing parts of the machine
- The machine is in upright working position
- The protection devices are working properly.

PROTECTION DEVICES

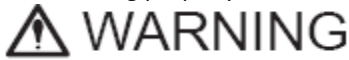

WARNING

- The machine is equipped with several protection devices including the following:
 - A protection skirt and a hood for protecting the tool plates.
 - These devices protect the operator and/or others persons from potential injuries. Do not remove them. On contrary, before using the machine, please ensure that all protection devices are mounted and function properly.
 - The Envirogard Emissions Monitoring System

ARREST FUNCTIONS



WARNING

- Functions of arresting of the machine are following:
 - Switch to stop the engine
 - Button to stop the grinding movement
 - Close the propane tank

SAFE USE



WARNING

- The LAVINA® 25G-S is designed to eliminate all risks correlated with its use. However, it is not possible to eliminate the risks of an eventual accident with the machine. Unskilled or uninstructed operator may cause correlated residual risks. Such risks are:

- Position Risks due to operator's incorrect working position
- Tangling up Risks due to wearing inappropriate working clothes
- Training Risks due to lack of operational training

PROPANE SAFETY



WARNING

- Propane is a flammable gas whose vapors are heavier than air. As is the case with gasoline, propane can explode if the proper cautions are not heeded. Propane is odorized with an agent having a distinct odor that is recognizable at very low concentrations. This helps in identifying leaks, even when they are small.

FIRE SAFETY



WARNING

- Be aware of the potential dangers of fire or explosion when using propane, and take normal fire-safety precautions.
 - Fire:** There is a possibility of fire from LPG vapor leaking or venting from fuel cylinders or carburetion equipment.
 - Explosion:** LPG vapor concentrated or confined to a small, restricted space may explode or ignite.
 - Propane** may experience a **BLEVE**, a boiling liquid expanding vapor explosion.

EMISSIONS



WARNING

- All propane powered floor care machines produce emissions. Most are harmless, but some are dangerous and can be fatal. Carbon monoxide (CO) poses the greatest risk, since CO can be lethal within as little as 30 minutes exposure at 3,000 parts per million (ppm) concentration.
- Carbon monoxide is an invisible, odorless, colorless gas created when fossil fuels (such as gasoline, wood, coal, propane, oil and methane) burn incompletely.

HAZARD COMMUNICATION



WARNING

- A **Material Safety Data Sheet** for propane shall be posted in all buildings where propane will be used.

Because propane is odorized, it is easily detected at levels of just a few parts per million, which is much less than the exposure limit of 1000 parts per million.

If you smell propane while operating a propane floor care machine, do the following:

Stop the engine:

1. Pull the throttle to the stop position (if present) or turn the key switch to the off position.
2. Shut off the service valve on the propane cylinder.
3. Move the floor machine to a well-ventilated area.
4. Remove the cylinder from the machine and take it outside the building.

5. If the cylinder is leaking, contact a DOT approved repair shop to determine the cause of the leak and have the shop, not you, repair it.

If a fire occurs while the machine is being operated, do the following:

1. Stop the engine: pull the throttle to the stop position (if present) or turn the key switch to the off position.
2. Shut off the service valve on the propane cylinder if possible. Be careful not to be burned.
3. Move the machine outside if possible. If not possible, move it to a well-ventilated area away from flammable materials.
4. Do not attempt to extinguish the flame from a gas leak. If you do, the gas will build up in the area and could re-ignite. Starve the fire by shutting off the supply of gas.
5. Have the machine and cylinder inspected before using them again.

LOCAL AGENCIES AND REGULATIONS

• **NFPA**

Operating a propane powered floor care machine requires compliance with certain safety regulations. The National Fire Protection Agency (NFPA) Standard for Storage and Handling of LP Gas is the appropriate authority for safe propane use. A copy of this publication is available through the NFPA in Quincy, MA (1-800-334-3555).

Among its regulations, NFPA #58 requires that all personnel employed in the handling of propane gas be trained in its proper handling and operating procedures. It also requires them to carry a written certification from their employer or training supervisor to attest to such training. Although this is directed mainly to those who fill and transport liquid propane gas, Onyx Environmental Solutions recommends that operators of propane powered floor care machines in public places be trained and certified as well.

With regard to operation of propane powered floor care equipment, even though NFPA 58 8-4.5 says “these machines shall be permitted to be used in buildings frequented by the public, including the times when such buildings are occupied by the public,” Onyx Environmental Solutions suggests usage when occupancy of a given work area is minimal.

• **CARB / EPA**

The California Air Resource Board (CARB) and Environmental Protection Agency (EPA) also set limits for propane-powered engines used outdoors, but CARB/EPA approval does not signify that the engine is safe to use indoors.

• **CGA**

The Canadian Gas Association (CGA) has set a limit of 1500 ppm CO in exhaust flow.

• **OSHA**

For propane powered machines used indoors, the Occupational Health and Safety Administration (OSHA) has established a limit of 50 ppm CO for 8-hour time weighted average (TWA) in ambient air and is considering a limit of 800 ppm CO in exhaust flow.

• **DOT**

The Department of Transportation (DOT) has established regulations regarding the safety of fuel cylinders including the ones used on propane powered floor care machines.

• **Local Agencies**

Local law enforcement agencies such as the local Fire Marshall also rely on independent testing labs such as UL and CGA before giving their approval of the use of some equipment. These labs thoroughly test equipment and submit their stamp of approval only after rigorous testing. While not being required by all law enforcement agencies, the stamp of approval by these agencies further assures the operator that he or she is working with and around safe equipment.

NOTE: In order to reduce all consequences of the above-mentioned risks, we advise that machine operators will follow the instructions in the manual at all times.

RESIDUAL RISKS

- During the normal operating and maintenance cycles, the operator is exposed to few residual risks, which cannot be eliminated due to the nature of the operations.

BEFORE YOU BEGIN

- Working area must be clear from any debris or objects.
- A first-time operator must always read the manual and pay attention to all safety instructions.
- All propane connections and cables must be inspected for potential damages.
- Perform general daily inspections of the machine and inspect the machine before each use.
- Always inspect the safety devices:
- The tool protector must be working
- Mount the security disc when working with Quickchange Pads.
- The machine must be clean
- Never operate the machine in the rain!
- Confirm that there are no missing parts especially after transportation, repair or maintenance.
- Before filling the water tank with water make sure the machine is not working and the main switch is turned off.
- Before turning on the machine make sure that the base is placed on the floor, the machine **MUST NOT** be in an upright position when turned on!

OPERATING MACHINE

- When operating the Lavina® 25G-S, make certain that there is no one, but you around the machine.
- Never leave the machine unattended while working.
- The water hose must move freely and must be damage-free.
- Check if the floor, you work on, is not too uneven. If this is the case, it may damage the machine.

AFTER WORK IS COMPLETED

- Clean the machine and its surroundings properly
- Empty and clean the water tank
- Store the machine in a safe place
- Place the Propane bottle outside in its storage



THE WORK AREA**WARNING**

- Make certain that people or vehicles do not enter the work area.
- Avoid cables and hoses being in the way.
- Always check the floor for debris

PERSONAL PROTECTIVE EQUIPMENT (PPE)**WARNING**

- Always wear safety shoes when working with the machine.
- Always wear ear protectors when working with the machine.
- All personnel in the immediate work area must wear safety glasses with side shields.
- Always wear safety gloves when changing the tools.
- Always wear clothes suitable for the work environment.
- Always wear Carbon Monoxide Indicator badges as an extra precaution.
- The plastic indicator contains a colored indicator button that darkens in the presence of Carbon Monoxide. The relative darkness of the indicator button indicates the level of CO in the ambient atmosphere. Most indicator badges have a useful life of 30 days, depending on the concentration of contaminants, humidity, and temperature.

TESTING**WARNING**

- There are a great number of instruments offered on the market to test for toxic gases. Only those designed to read carbon monoxide resulting from combustion engines is considered acceptable for testing exhaust emissions from propane powered floor machines.
- Some instruments are used to read “ambient air” and may be damaged if used to take readings in the muffler or tail pipe. Selecting the proper instrument is an important part of meeting the testing requirements.
- Generally speaking, units capable of reading in ppm, (parts per million), at ranges from 0 to 1000 are adequate for checking ambient air (air in the breathing zone of the operator). Instruments capable of testing carbon monoxide in the exhaust should be able to read from 0 to at least 2000 ppm and should be certified by the manufacturer for that purpose.
- Some instruments and systems used for these purposes are:

1) **AMBIENT AIR MONITORING**

DRAGER Model 190: Manufactured by National Drager.
 SENSIDYNE gas sampling system with YB-11038 Sensidyne detector tubes
 DRAGER gas sampling system with YB-4620 Drager detective tubes
 GAS-TECH Model CO-95
 ENERAC POCKET 60: Manufactured by Energy Efficiency System

2) **ENGINE EXHAUST ANALYZERS**

HORIBA GAS ANALYZER

- ENERAC 2000 COMBUSTION ANALYZER
 ENERAC POCKET 60
- 3) **DATA LOGGERS**
 INDUSTRIAL SCIENTIFIC CORP. MODEL STX-70
 CO MONITOR, Data-Logger
 BIOSYSTEMS INC. “TEXILOG” Data-Logger

- All instruments used for testing must be calibrated at intervals recommended by the manufacturer. The monitor, model number and date of calibration will be recorded with all test results.

OPERATOR**WARNING**

- The operator must know the machine’s work environment.
- Only one operator at a time can work with the machine.
- The operator must be properly trained and well instructed prior operating the machine.
- The operator must understand all the instructions in this manual.
- The operator must understand and interpret all the drawings and designs in manual.
- The operator must know all sanitation and safety regulations pertaining to the operation of
- The operator must have floor grinding experience.
- The operator must know what to do in case of emergency.
- The operator must have an adequate technical knowledge and preparation.
- The operator is expected to operate their equipment safely and responsibly. They are responsible for the proper handling and storage of propane cylinders, identifying potential hazards associated with his job and avoiding these hazards at all times.

PROPANE CYLINDERS**WARNING**

- The Propane cylinders are constructed of either aluminum or steel. We recommend aluminum because it is lighter and guards against rusting. The cylinder used on propane powered floor machines is classified as a 4E240 cylinder. Its rated capacity is 20 lbs. and this designation refers to the model of the cylinder. Actual propane capacity achieved during filling can be less than, equal to, or slightly more than 20 lbs. Use only UL, CTC/DOT listed cylinders.
- The propane cylinder used on the floor machine is a motor fuel cylinder as listed by the Department of Transportation. Unlike the common 20-lb propane outdoor grill cylinders (which are not legal for use on propane floor machines), the motor fuel cylinder has a number of safety systems designed into it to ensure your safety at all times.
- There are two types of 20 lb. motor fuel cylinders.
 - Liquid draw
 - Vapor draw
- The liquid draw cylinder is used on larger vehicles like forklifts. These machines have special vaporizing carburetors to allow the propane to change from a liquid to a gas before being burned in the combustion chamber.
- The vapor draw cylinder is used on small machines like the propane powered floor care machines. The vacuum generated by the engine draws up the Propane gas vapor through the fuel system. The propane powered floor care

machine does not have an evaporating system and will freeze up if liquid propane is introduced to it. It is necessary that special attention be paid to ensure that neither the liquid nor the vapor draw cylinders be overfilled.

REFUELLING CYLINDERS WARNING

- The proper filling of propane cylinders is a subject so important that it warrants special attention. Propane cylinders should only be filled by qualified propane dealers.
- Most important, propane cylinders should be filled no more than 80% of their rated capacity. The other 20%, which is about 4" (10 cm) from the top of the cylinder, is called the vapor space or headspace. This vapor can be compressed without causing the pressure relief valve to open and vent gas to the area around the cylinder. If there is no headspace to allow for fuel expansion, the pressure relief valve will open, releasing propane gas into the atmosphere. This is a very dangerous and volatile situation as there is always the possibility that enough of the vented gas could find its way down to the floor and come in contact with a pilot light from a furnace, hot water heater, or other source of ignition. Propane changes into a gas, is -44° F (-42° C). Exposing unprotected skin to propane gas or liquid could result in frostbite injury.
- All new cylinders should be vented and purged of air per manufacturer's instructions before use. Never bleed propane cylinders indoors.

STORAGE CYLINDERS WARNING

- When not in use, propane cylinders always should be stored outside in an upright position in a secure, tamperproof, steel mesh storage cabinet. This cabinet may be located next to the building but with at least five feet (1.5 m) of space between the cabinet and the nearest building opening (door or window), also away from heat and direct sunlight.

- Do not install the cabinet near a stairway or street elevator as vented propane gas will seek a lower level since it is heavier than air and could find its way into the basement of the building. Do not store cylinders full or empty inside a building or inside a vehicle. Although it is unlikely that propane will vent from a stored cylinder, if it should, the vapor could come in contact with an ignition source such as a spark from a power tool or other appliance and create a flash fire.
- Do not smoke or use a device with an open flame when handling or transporting propane cylinders.

TRANSPORTING CYLINDERS WARNING

- When transporting cylinders to a propane dealer or to a job, make sure the cylinders are securely fastened and standing in an upright position with the service valve closed.
- A cylinder rattling around in the back of a vehicle and banging into other objects constitutes a hazard. Avoid dropping or banging cylinders against sharp objects.
- The propane cylinders are sturdily constructed but a series of hard jolts could cause damage.
- Please note that any cylinder that has been filled is always considered full, no matter how little propane gas remains in it. This is because even when all liquid has evaporated into vapor there is still some propane gas vapor left in the cylinder. Because this remaining fuel is flammable, an empty cylinder should be treated with the same careful procedures as one that is filled to the 80% level with liquid propane. The only time that a cylinder is considered empty is when it is new, before it has been filled with propane.
- When transporting a propane powered floor machine, the propane cylinder may be strapped onto the machine as long as the machine itself is firmly secured in the vehicle.
- Of course, spare cylinders should always be secured in an upright position

3. HANDLING AND TRANSPORTATION

ADJUSTING THE HANDLE



Figure 3.1



Figure 3.2



Figure 3.3

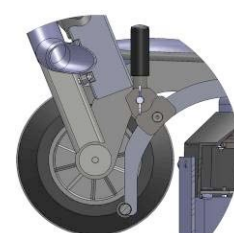

Figure 3.4a

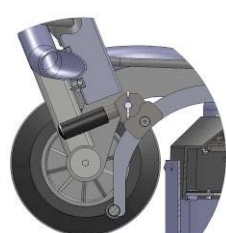

Figure 3.4b

The Handle on the frame is adjustable in height and allows the operator to work in a correct and safe posture. Turn the handle in the upright position to change the tools (Fig. 3.1, Fig. 3.2, Fig. 3.3). Choose the upright position to move easy the machine (Fig. 3.3).

To avoid turning the head during transport should be unscrewed the (butterfly, wing-headed) screw and move the lever from the position shown in Fig.3.4a to position Fig.3.4b.

When the machine operates the lever must be in position shown in Fig.3.4a, in order to rotate the head when change the tool.



Figure 3.5



Figure 3.6

LIFTING THE MACHINE FROM WORKING TO TOOL MOUNTING POSITION

Push the front handle down and swivel it to the front (Fig. 3.5). Pull the handle up and ensure the head is a stable upright position, for mounting/dismounting the tool. Ensure that the water tank is empty before flipping the machine. Pull the head in upright position (Fig. 3.6).



Figure 3.7

LIFTING

Lifting the machine by crane is possible by using the eye bolt mounted on the carriage (see fig. 3.7). The eye bolt and machine construction is rated only for the weight of the machine. Do not lift any other loads on the machine. Use always hoisting equipment rated for 300 kg or 660 lbs.

STORAGE

Always store and transport the LAVINA® S machine in a dry place. Never transport the LAVINA® S machine unprotected; it may be damaged if transported unprotected during rain or snow.

4. OPERATION

PRELIMINARY CONTROLS

Inspect the working area as explained in the safety instructions. For wet use, fill in the water tank or connect the vacuum extractor and ensure that the vacuum hose is clear and it will follow the machine easily.

Make sure the bonnet air filter on top of the engine is clean. It should be cleaned hourly.

Check the engine oil level, screw the dipstick in to get reading. See to it the tank is fill up (see also "Storage Propane tanks).

TANK and FUEL LINES - The tanks has already been covered but do the fuel lines show any sign of wear and tear, such as cracks or any corrosion. Screw the brass fuel line fitting onto the tank service-valve hand tight only. This connection **MUST** be secure because the service valve has a safety valve inside it, which will only open if the brass fuel-line fitting is **COMPLETELY** seated into the service valve.

WATER FLOW CONTROL UNIT



Figure 4.1a



Figure 4.1b

The operator can choose the water sprays in the front (Fig.4.1a) when the level of the tap is in the horizontal position (Fig.4.1b), when the level is in the vertical position water will spray under cover of the machine.

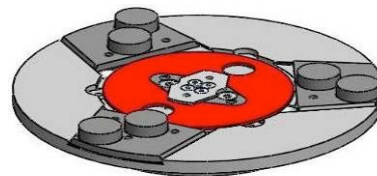

Figure 4.2



Figure 4.3

ADJUSTING AND MOUNTING TOOLS

Mount the tools only after ensuring that there is enough diamond bond material left. Be sure that the plates are always clean before mounting. **WARNING:** Secure always the "Quickchange" pads with the security plate (Fig.4.2), lock with the tool holder key (Fig.5.3). Diamond tools with Velcro are attached on three foam plates of 9 inch (Fig.4.3). The foam plates are ounted on the key lock (butterfly).Always use the tool holder key (Fig.5.3).

FRAME BLOCKING (U-JOINT)

The relation between the working head and the trolley is the frame (U-joint), which allows rotation about two perpendicular axes to better follow the profile of the floor.

The movement along the one axis can be fixed with two screws (Fig.4.4) and that block the lateral movement of the machine.



Figure 4.4

THE CONTROL BOARD

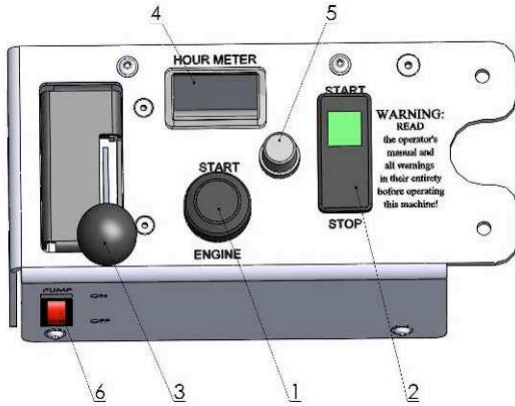

Figure 4.5

- 1 Start/Stop Engine switch** Turn key to the right for contact full right for starting the engine, to stop key to left full left is contact
- 2 Start/Stop clutch** Start will electronically activate the grinding plates to spin, by pushing stop it will disconnect engine from grinding heads
- 3 Throttle** Push forward to accelerate.
- 4 Digital RPM/workings hours indicator** When the motor runs it indicates the revolutions per minute of the motor, see the conversion table to know the rpm of the tools. When the motor does not run, it indicates the worked hours. The hour meter will blink between 48-52 hours as a reminder for oil change.
- 5 Fuse** Fuse 30 Amps for the electrical system.
- 6 Water pump switch** Lights orange when the water pump is working.

Rpm engine	rpm tools
2000	650
2100	683
2200	715
2300	748
2400	780
2500	813
2600	845
2700	878
2800	910
2900	943
3000	975
3100	1008
3200	1040
3300	1073
3400	1105
3500	1138
3600	1170

STARTING THE MACHINE

First, follow the directions in chapter Safety Devices and Safety Instructions. Check oil level. Open (counterclockwise) the service valve on the propane tank about one and a half turns. Next, see to it the Start/Stop clutch button (2) is in stop position check the throttle (3) in the IDLE position. This creates a vacuum necessary to open the lock-off valve inside the regulator. Actuation of the throttle lever will keep the lock-off valve from opening and the engine from getting fuel so the engine will not start. Proper maintenance will insure easy starting. Engage starter (1) for a **MAXIMUM** of 5 to 6 seconds or until the engine fires. Serious starter damage will result if this is exceeded and the warranty may not apply. Operate the engine at half throttle for approximately two minutes for proper warm-up. Then advance to full throttle for best results. If working wet, add water to the floor surface. If working dry, omit this step, and instead, switch on the vacuum unit. Finally, hold the machine firmly and push the start of the Start/Stop clutch button (2).

OPERATING THE MACHINE

Guide the machine in straight lines across the floor, and with each new line overlap a little bit of the previously completed surface. Work at a constant speed allowing the tools time to work at a speed appropriate for the tools' grit size. Avoid vibrations. Do not stop the LAVINA® S machine in one spot while the tools are still working because they will leave marks on the floor surface. When working wet, open the water tank periodically to release water onto the floor surface. When working dry, check the floor surface periodically to ensure that dust is not accumulating on the surface, also check regularly if your vacuum works properly.

STOPPING THE MACHINE

The stopping of the machine must be done gradually until the motor stops. Do not stop moving the machine before arresting the clutch as the tools could damage the surface. To stop push Stop clutch button (2), then close (clockwise) the service valve on the propane tank. ALWAYS allow the engine to run until it stops from lack of fuel. • **ONLY IN AN EMERGENCY** should the "stop" position on Start/Stop Engine switch (1) Disconnect the fuel line from the tank. REMEMBER, when you are finished with the machine, store the propane tank outside the building, in a **SECURE** place away from heat or direct sunlight. Use the Emergency button (9) only in emergency or use it to switch the power totally off. Remember not to hold the machine in one spot before turning off until the grinding plates stop moving.

ALARM

EnviroGard employs a sensor (Fig. 4.6) in the exhaust path between the engine and the catalytic muffler to detect the oxygen content of the exhaust before it is passed through the catalyst. The oxygen sensor does not react to nor does it measure the CO content of the exhaust. It responds only to oxygen content.



Figure 4.6

- The Control Module is set to ignore the readings from the oxygen sensor during the first three minutes the engine is running. This period allows: The sensor to reach a stable operating temperature.
- The catalyst in the muffler to reach the temperature necessary to reduce the levels of CO, nitrogen oxides (NOx) and hydrocarbons (HC) in the exhaust.

The most common event in which the Control Module shuts down an engine is when the air filter becomes dirty enough to restrict the air intake flow, which changes the air-fuel ratio such that the oxygen sensor signal is outside the control limits. Once the air filter is properly cleaned, operation of the machine can be resumed.

5. TOOLS AND ACCESSORIES

WEIGHTS



Figure 5.1

Superabrasive offers additional weights for increasing the productivity of the machine (Fig.5.1). Each additional weight weighs about 64 lbs or 29 kg. Each individual application, type and condition of surface, power capacity of the outlet, etc. will determine the number of weights you can use without tripping a breaker. The weight stacks on to three posts around the outer bowl (Fig.5.2). The additional weights depend on the tools; it is not always possible to add weights. Some tools work too aggressively and the machine can stop. The weight can be ordered with item number A08.00.00.00



Figure 5.2

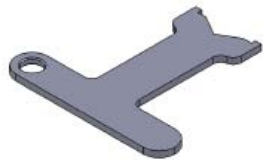

Figure 5.3

TOOL HOLDER KEY

The tool holder key (Fig. 5.3) is used for adjusting, mounting and dismounting of the foam plates. Always use the key for mounting. Item number is A03.00.00.00



the foam plate 13.5" (Fig.5.4). The "QuickChange" System.

FOAM PLATE

Diamond tools with Velcro are mounted on the foam plate. The foam plate is mounted on the

Item number is LV-9-FP-S

Figure 5.4

SECURITY PLATE FOR QUICKCHANGE PADS

Plate (Fig.5.5) used to ensure the "Quickchange" pads.

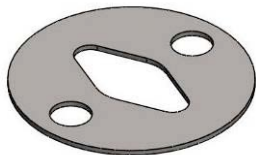

Figure 5.5

6. POPULAR TOOLS

RECOMMENDED TOOLS



QuickChange System and Tooling feature extremely fast and convenient tool changes, and a long tool life, providing for great long-term cost savings. The QuickChange pads are produced in four different bonds for super hard, hard, medium and soft concrete, in a variety of grit sizes, with either 1 or 2 buttons, which allows you to customize the aggressiveness of the cut.

Calibra grinding discs: our popular ceramic bond discs are designed for the removal of difficult scratches and they save you valuable time by eliminating the need for multiple passes with metal tools. They can be used wet or dry, and are best for hard concrete applications. They are with Velcro attachment.



NATO® polishing discs feature a special resin formula designed for both wet and dry applications and a unique design with wide channels allowing for work on a cleaner surface and ensuring a quality polish. Available in 3 and 4 in sizes. They are with Velcro attachment.

V-HARR® Premium Polishing Pads are designed for mechanically polishing and restoring concrete; also ideal for terrazzo and hard stone floors. V-HARR® pads are offered in a wide variety of diameters and grit sizes to accommodate many applications. Dry use is strongly recommended.

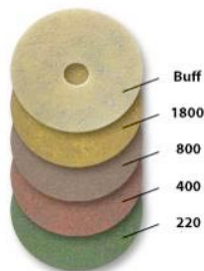

Diamo-Clean pads are high quality diamond-impregnated pads for floor maintenance. Available in a variety of sizes, they are designed for use under swing machines and burnishers, and are great for daily use – they require only water (no wax or chemicals needed) and are a very environmentally friendly solution for maintaining floors.

Use only Superabrasive’s recommended tools see www.superabrasive.com

7. EXPLODED VIEW

LAVINA® 30G-S GENERAL EXPLODED VIEW (FIG.7.1)

LAVINA® 30G-S TOP COVER EXPLODED VIEW (FIG.7.2)

LAVINA® 30G-S PLANETARY DRIVE EXPLODED VIEW (FIG.7.3)

LAVINA® 30G-S
TOP COVER
EXPLODED VIEW 1
(FIG.7.4)

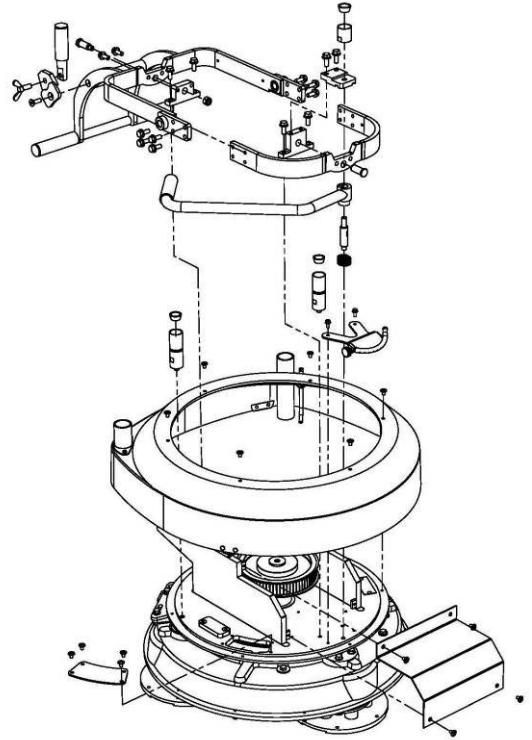
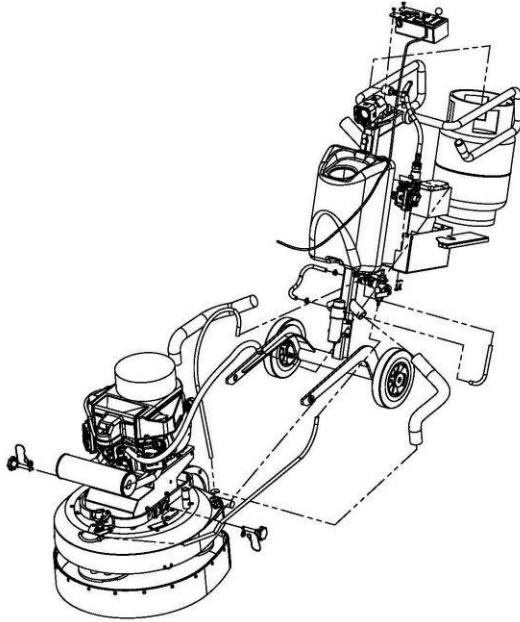
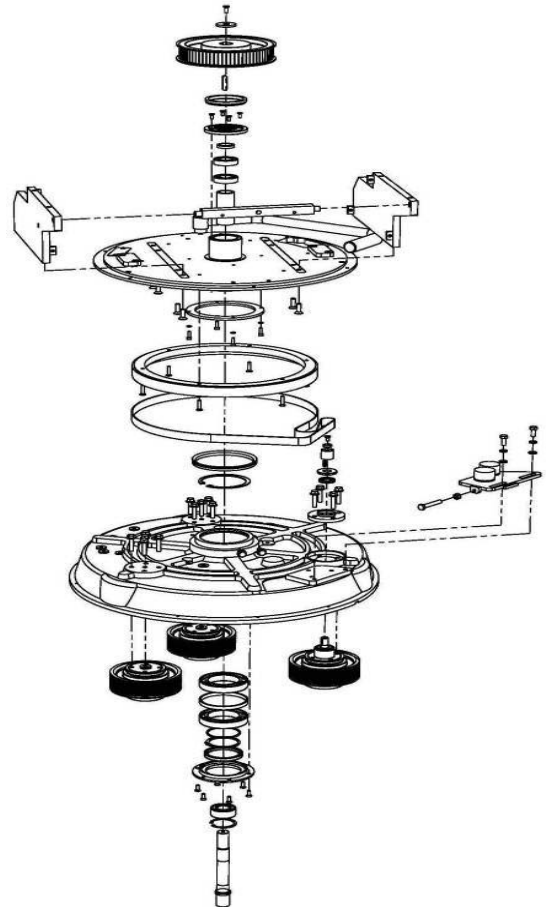

Figure 7.2



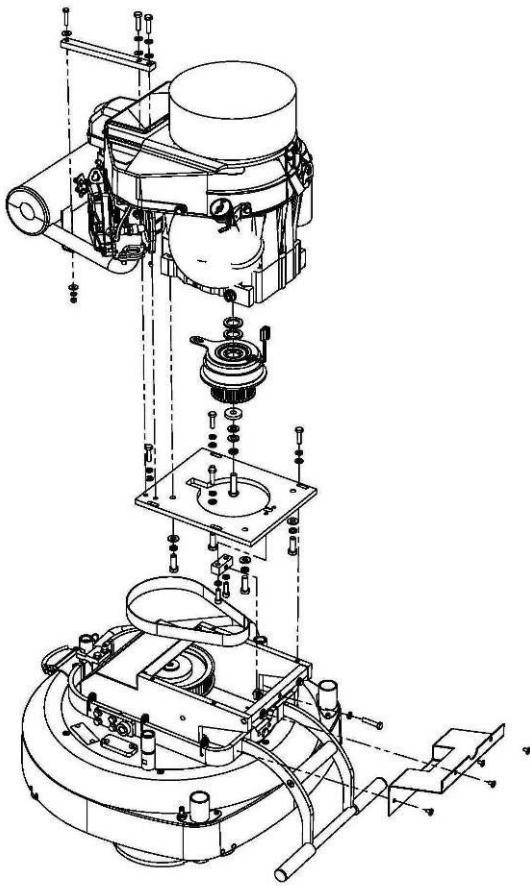

Figure 7.3

Figure 7.4

- LAVINA® 30G-S BOTTOM COVER EXPLODED VIEW 1 (FIG.7.5)
- LAVINA® 30G-S BOTTOM COVER EXPLODED VIEW 2 (FIG.7.6)
- LAVINA® 30G-S CARRIAGE EXPLODED VIEW (FIG.7.7)
- LAVINA® 30G-S TOOL HOLDER EXPLODED VIEW (FIG.7.8)

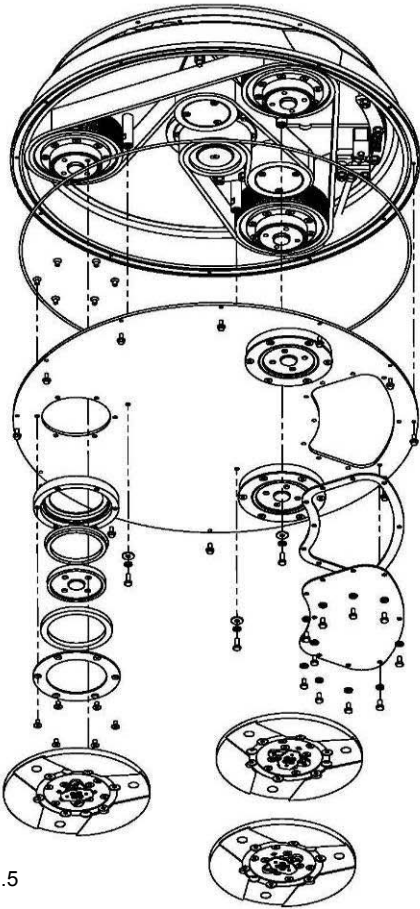

Figure 7.5

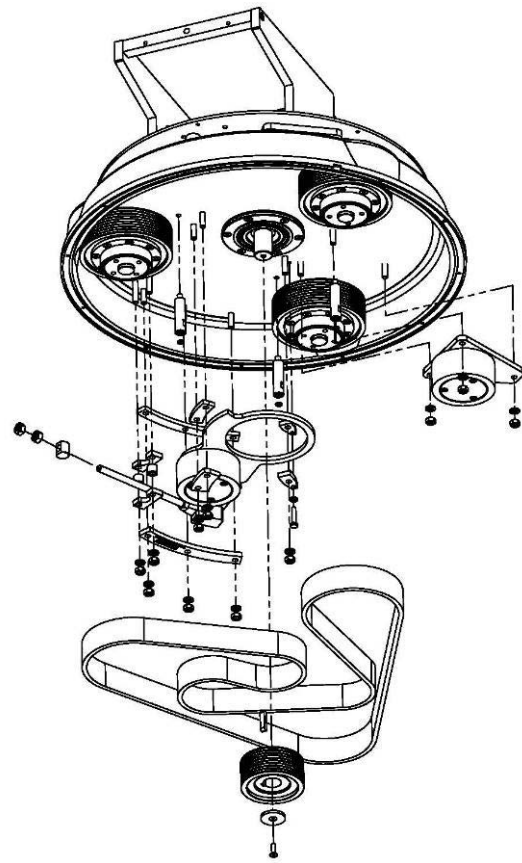

Figure 7.6

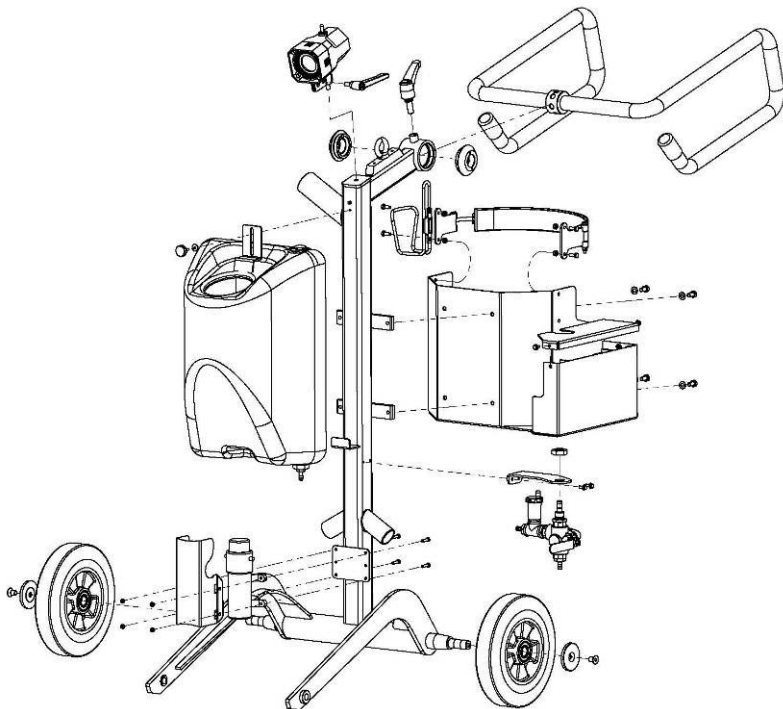

Figure 7.7

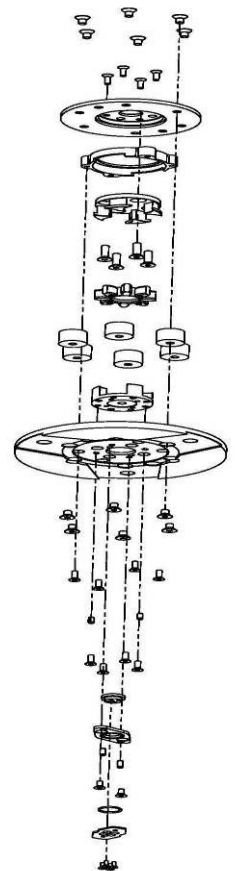

Figure 7.8

8.MAINTENANCE AND INSPECTION

REMARK

Tampering w/Emission Control System Prohibited

Federal law and California State law prohibits the following acts or the causing thereof: (1) the removal or rendering inoperative by any person other than for purposes of maintenance, repair, or replacement, of any device or element at design incorporated into any new engine for the purpose of emission control prior to its sale or delivery to the ultimate purchaser or while it is in use, or (2) the use of the engine after such device or element of design has been removed or rendered inoperative by any person.

Among those acts presumed to constitute tampering, involve the parts/systems listed below:

- Carburetor and internal parts
- Spark plugs
- Magneto or electronic ignition system
- Fuel filter element
- Air cleaner elements
- Crankcase
- Cylinder heads
- Breather chamber and internal parts
- Intake pipe and tube

MECHANICAL PARTS

Parts such as the belt, seal rings, cap rings, spiders, buffers, guard assembly, tires are subject to wear and should be replaced as needed.

CLEANING

Keep your machine clean. Cleaning the machine on a regular basis will help detect and solve potential problems before they cause damage to the machine. Most importantly, check and clean the tool plate connections, vacuum hoses, water tank and the Propane installation.

CHECK HOURLY

BONNET FILTER - Make sure the bonnet air filter atop the engine is clean. It should be changed hourly and thoroughly cleaned before reuse. The same for the recoil dust filter. If neglected the engine will overheat and carbon monoxide emissions will elevate.

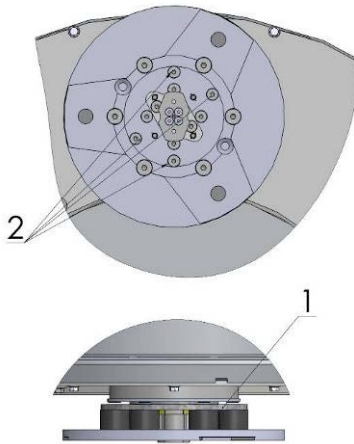

Figure 8.1

CHECK DAILY

After operating the Lavina® S machine, the operator should conduct a visual inspection of the machine during cleaning the whole machine. Any defect should be solved immediately.

Check oil level daily.

Tool holders: Buffers and spiders are consumables and must be visually checked daily and replaced if needed. See flanges or discs are mounted locked well in place The key lock holders (butterflies) should be also checked.

Check the rubber buffers and fixing of the holders. The flange holding the buffers (Fig.8.1 1)has to be firmly fixed to the unit. A gap seen there means that there are loose screws fixing the holder. The screws has to be tightened immediately for safety operation. Working with loose screws on the holder could also cause bad damages on the machine. Tightening force of the screws has to be 25...30N.m(18...22 ft/lbs).

It is very important to check regularly the screws(Fig.8.1 2),that fix the "Quickchange" holder to the safety part, so that holder will not fly away if the buffers got damaged

"Quickchange" sleeves should be clean. The tension of the planetary belt can be daily checked by moving the main head and feeling the resistance of the moving pulleys, if the belt slips tension immediately, like described in the chapter Troubleshooting .

CHECK AND REPLACE AFTER THE FIRST 8 WORKING HOURS

Replace the oil in the engine after the first 8 hours work, according to the instructions of the engine manufacturer.

Always use 30HD or 10W30 engine oil with all of the following ratings: SF, SG, and CC

CHECK AND REPLACE AFTER THE FIRST 15 WORKING HOURS

Check the belt tension after 15 hours working with the machine.

The bottom cover has a control cover (Fig. 8.2) that allows fast and easy control and correction of the belt. It is recommended to check the tension of the belt after the first 15 hours and to tighten if necessary. For the correct tension, see TROUBLESHOOTING "mounting the belt". Every time you open the control cover, mount back all the screws with washers.

CHECK AND REPLACE EVERY 50 WORKING HOURS

Change engine oil, while changing check for leakage of engine oil at the various seals. The hour meter will blink between 48-52 hours as a reminder. /"Engine Oil Capacity" is 1.5L(1.6US.qt) when oil filter is not removed 1.7L(1.8US.qt) when oil filter is removed/.

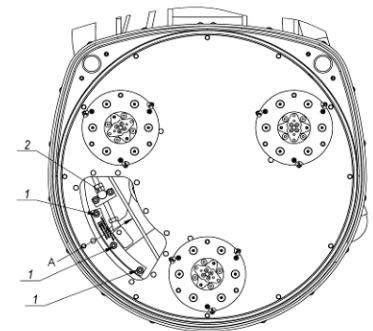

Figure 8.2

Recommended Oil Change Intervals

Do not exceed the 50-hour oil change interval. Oil changes more frequent than 25 hours will give even longer engine life. In any case, always use 30HD or 10W30 engine oil with all of the following ratings: SF, SG, and CC. make sure the oil level is maintained at the "FULL" level.

CHECK AND REPLACE EVERY 200 WORKING HOURS

Every 200 working hours the operator should inspect all parts of the machine carefully. Most importantly, inspect and clean the tool plate connections, vacuum hoses and water tank. Also, check the water flow. Check the guard assembly. Make certain the wheels are clean and rotate properly. Inspect the control buttons. If there are defective control parts, they should be replaced immediately. Replace worn vacuum- and water hoses.

Carefully inspect the seal rings and bearings of the grinding units, and replace any showing signs of excessive wear. For more information, refer to chapter troubleshooting below.

Dismount the tool holders (See Troubleshooting) replace all parts (Spider, buffers, sealer caps, "O" rings) with the slightest damage or consume. Open the checking cover on the motor base to check of the planetary driving belt, by moving the main head the belt should not slip on the planetary pulley and drive the pulleys. **Return** machine to **authorized service center** for overall checkup of the Engine. For Propane safety, have the machine serviced by a **Certified Technician**, including emission check.

CHECK AND REPLACE EVERY 400 WORKING HOURS

Besides the checks of 200 working hours, replace sealer and V-rings like described in chapter "TROUBLESHOOTING REPLACING BELT AND PULLEY UNITS. Check if belts and bearings are in good condition, change if needed.

Return machine to authorized service center for overall checkup of the Engine. For Propane safety, have the machine serviced by a Certified Technician, including emission check.

VACUUM

As stated previously, frequently check hoses and other parts for clogging.

WATER LEAKS

Replace any leaking parts immediately as the water could damage your machine

MECHANICAL PARTS

Parts such as the belts, seal rings, cap rings, spiders and buffers and guard assembly are subject to wear and should be replaced as needed.

ELECTRICAL SYSTEM

Dust should not enter the control box, as it will destroy the contacts. Remove (blow out) any dust present.

Electrical schemes with Kawasaki Engine

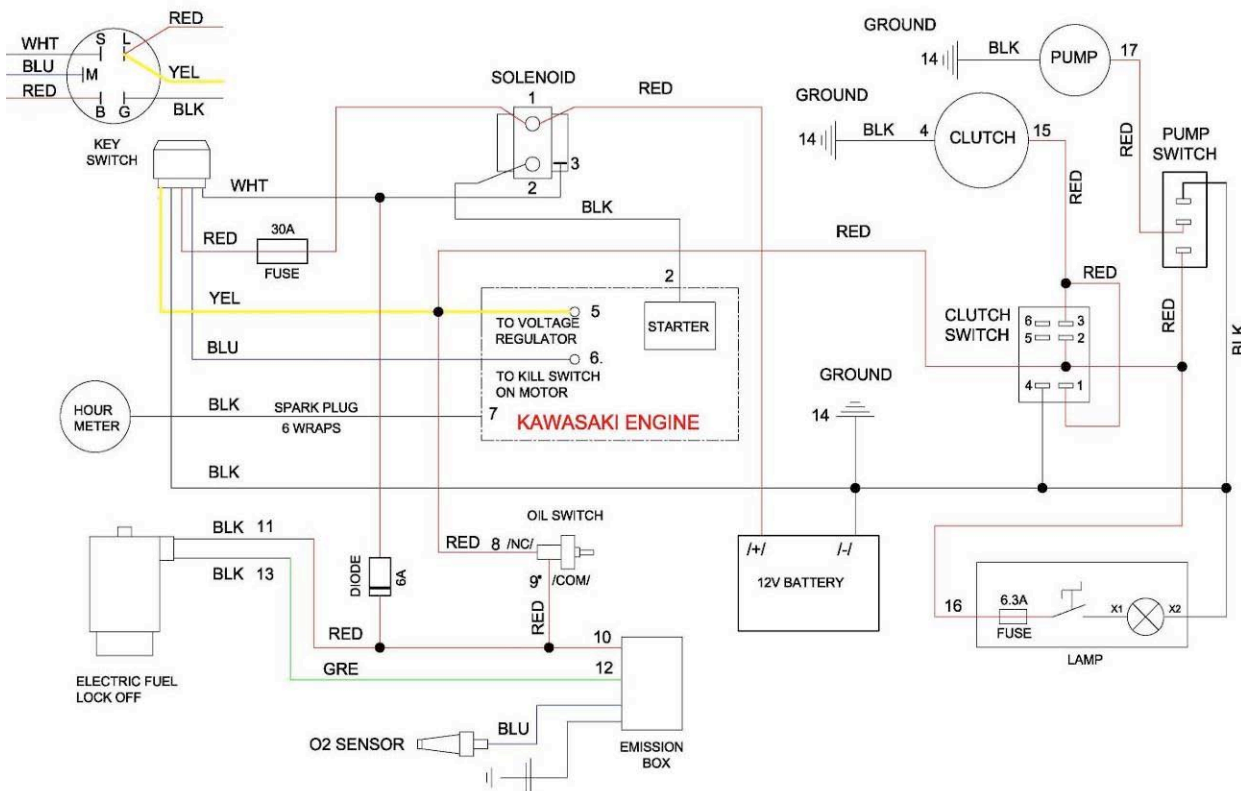

9. TROUBLESHOOTING

9.1 ENGINE

When troubles occur, be sure to check the simple causes which at first, may seem too obvious to be considered. For example, a starting problem could be caused by fuel starvation due to an empty propane cylinder or an unopened service valve. If you do not check for this, starter burnout could result.

Some Troubles and solutions:

Surging idle

To smooth out the engines' idle characteristics, adjustment is provided by an idle screw on the lower left side of the carburetor as viewed from the operator's position. The screw is bright steel and 1/4" in diameter with a Phillips head on it. Rotating the screw clockwise will increase the idle speed and this should cure the "surging idle". If it does not, call our customer service.

Engine starts and idles, but will quit as the throttle is advanced

It is possible that the propane tank's service valve is faulty. To check for this, close the valve completely and then reopen very slowly while you listen for a "click" when the gas begins to travel through the valve. If you hear this very slight noise, the valve is only partially opening. This allows enough gas through to start and idle the engine, but not enough for full throttle operation. As the throttle is increased, allowing more air to enter the intake, the engine will quit from fuel starvation. Call your dealer or the factory for instructions on where to have the service valve replaced. Meanwhile, to get by, you can continue to open the service valve until you do not hear a "click" and then the engine will run normally. If it does not, call your customer service.

Starter barely turns the engine over or the solenoid just clicks

The battery is likely low in charge. This can be remedied by recharging the battery using a 12 Volt battery charger at 4.12 amperes. The battery is located under the frame at the rear of the buffer. The positive post is the one with the RED cable attached to it. Follow the instructions that came with the battery charger. REMINDER: this will continue to happen unless your engine is run for sufficient time between starts to recharge the battery.

9.2 CHECKING AND CHANGING OIL



Figure 9.2.1



Figure 9.2.2

Check the engine oil level, screw the dipstick in to get reading. While changing engine oil, check for leakage of engine oil at the various seals. The hour meter will blink between 48-52 hours as a reminder.

Recommended Oil Change Intervals

Do not exceed the 50-hour oil change interval. Oil changes more frequent than 25 hours will give even longer engine life. In any case, always use 30HD or 10W30 engine oil with all of the following ratings: SF, SG, and CC. make sure the oil level is maintained at the "FULL" level.

9.3 SEPARATING THE HEAD FROM THE CARRIAGE

Please note that the propane cylinder has to be removed and stored outside before any maintenance or reparation is done.



Figure 9.3.1



Figure 9.3.2



Figure 9.3.3

Pull the connector of the battery (Fig. 9.3.1), pull out the Propane hose (Fig. 9.3.2), the connectors of the lamp (Fig. 9.3.3), dismount the control panel (Fig. 9.3.4), and take off all water and vacuum hoses (Fig. 9.3.5). Remove the tank (Fig. 9.3.6). Now it is possible to separate the head by removing the pins see to it two persons do this operation one person holds the carriage the other pulls the pins (Fig. 9.3.7),



Figure 9.3.4



Figure 9.3.5



Figure 9.3.6



Figure 9.3.7

9.4 DISMOUNTING/MOUNTING THE ENGINE



Figure 9.4.1



Figure 9.4.2



Figure 9.4.3

Separate head from carriage (see previous chapter). Remove front (Fig. 9.4.1) and back belt protection (Fig. 9.4.2). Loose the motor base plate (Fig. 9.4.3), release the tension device (Fig. 9.4.4), and take out the belt (Fig. 9.4.5). Take off the engine (Fig. 9.4.6).



Figure 9.4.4



Figure 9.4.5



Figure 9.4.6

Reassemble in the same manner. (Fig. 9.4.7), Tension the belt with bolt (4) on (fig. 9.4.6) or (fig. 9.4.4) The belt tension can be tested with a Frequency tension Tester Optibelt 3 TT or manual by pushing with a force of 6 kg or 13 lbs in point A, the deflection of the belt must be 3,1 mm or $\pm 1/8$ Inch

ATTENTION:
NEVER "OVER" TENSION THE BELT, THE BELT WILL BE DESTROYED AND IT WILL NEVER RECOVER ITS ORIGINAL TENSION

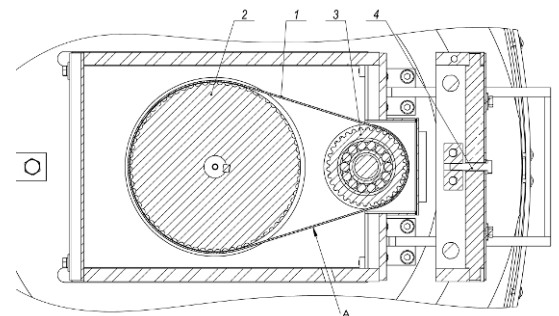

Figure 9.4.7

9.5 REPLACING THE CLUTCH

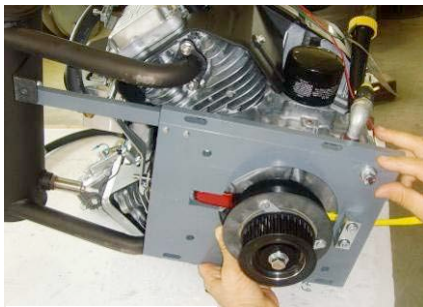

Figure 9.5.1



Figure 9.5.2



Figure 9.5.3



Figure 9.5.4

Incase the electric clutch has to be replaced, remove the engine (see previous chapter) and lay it on its side with the oil drainage up (Fig. 9.5.1). Remove the motor base plate (Fig. 9.5.2) and loose the front nut with an impact wrench to dismount the pulley and clutch (Fig. 9.5.3).

Reassemble in the same manner. Do not forget to mount back the washers on the shaft (Fig. 9.5.4). The torque on the front nut (Fig. 9.5.3) to mount the pulley and clutch should be 70 Nm or 52 ft lbs.

9.6 DISMOUNTING AND MOUNTING TOOL HOLDERS TO CHANGE BUFFERS AND SPIDERS, CHANGING V-RINGS AND FELT-RINGS



Figure 9.6.1



Figure 9.6.2



Figure 9.6.3



Figure 9.6.4

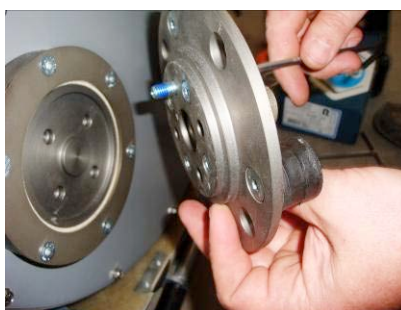

Figure 9.6.5



Figure 9.6.6

To check or replace the buffers and the spiders, the tool holders have to be dismounted. Remove the countersunk screws on top of the buffer (Fig.9.6.1). Take the disc off (Fig.9.6.2), the spider can be removed or replaced (Fig.9.6.3). By loosening four Hex cap bolts (Fig.9.6.4), the disc comes loose (Fig.9.6.5) and the buffers can be replaced (Fig.9.6.6). Attention, by mounting use always the "blue" thread locking adhesive, except on the bolts to lock the buffers (Fig.9.6.5). Use always original bolts. Depending on the number (3,4 or 6) of buffers, the holder can be more flexible or rigid.



Figure 9.6.7



Figure 9.6.8



Figure 9.6.9

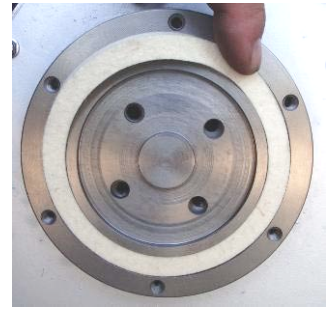

Figure 9.6.10



Figure 9.6.11

When the tool holder is dismantled, you can change the sealers (V-Ring and Felt-Ring). Take out Felt-Ring, Adaptor and V-Ring. Before mounting check on which side the adaptor is fitting, remember the correct side. Mount the V-Ring with the smallest lip of the V to inside (Fig.9.6.7) just push the V-ring so the top is on the same level as the pulley top (Fig.9.6.8). Then take the adaptor in the correct way and push the V-Ring down with the adaptor (Fig.9.6.9). The lowest lip of the V-Ring should only barely touch its gliding surface; also never push the V-Ring down with fingers. Mount now the Felt-ring on top (Fig.9.6.10). Close the sealers with the cap (Fig.9.6.11).

9.7 TENSIONING AND REPLACING THE PLANETARY BELT



Figure 9.7.1



Figure 9.7.2

If the belt slips or is broken, separate the carriage from main head (Fig. 9.7.1). Take off handles, fork, top frame and weight holders so you can push up the top cover (Fig. 9.7.2).

9.8 TENSIONING USED PLANETARY BELT



Figure 9.8.1



Figure 9.8.2

Noticing speed lost in planetary movement it is possible to tension the belt for planetary movement as described in 9.9 Mounting and tensioning a new planetary belt.

9.9 MOUNTING AND TENSIONING A NEW PLANETARY BELT



Figure 9.9.1

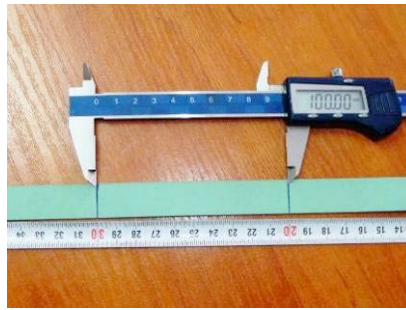

Figure 9.9.2

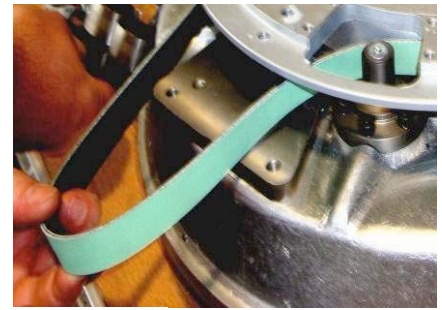

Figure 9.9.3

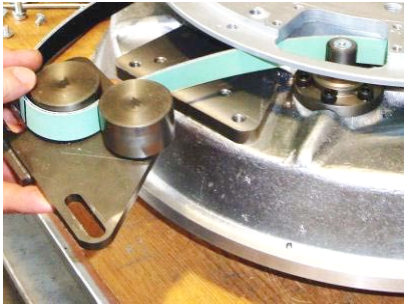

Figure 9.9.4



Figure 9.9.5

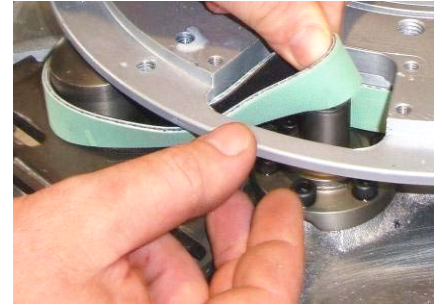

Figure 9.9.6

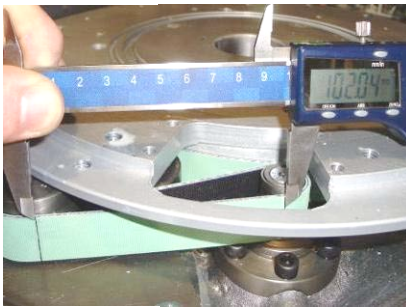

Figure 9.9.7



Figure 9.9.8

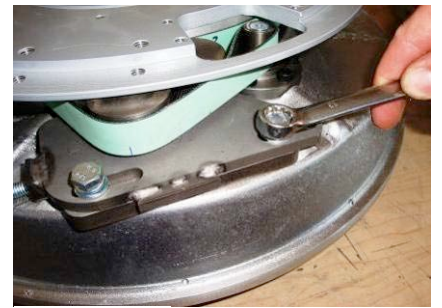

Figure 9.9.9

Dismount completely the tensioning device (Fig. 9.9.1). Make 2 signs on the dismantled belt exactly 10 cm out of each other (belt without tension) (Fig. 9.9.2). The purpose is to measure 10.2 cm on the belt in tension what is a tension of 2%, a maximum of 2.5% is allowed.

ATTENTION: NEVER "OVER" TENSION THE BELT, THE BELT WILL BE DAMAGED AND IT WILL NEVER RECOVER ITS ORIGINAL TENSION

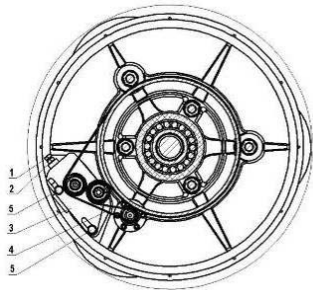

Figure 9.9.10

Mount the belt back around the planetary pulley; see that the belt is behind the driving pulley (Fig. 9.9.3). Put the belt around the left roller of the tensioning device (Fig. 9.9.4). Put the tensioning device back in place and pull the belt from the roller on the right side (Fig. 9.9.5). Put the belt around the driving pulley (Fig. 9.9.6). Begin to tension until the measure of 10 cm between the marks becomes 10.2 cm (Fig. 9.9.7) (Fig. 9.9.8). Tighten the tensioning device while turning the bolt move the planetary head so the belt can slide. (Fig.9.9.8). Do not forget to lock the tensioning device (Fig.9.9.9).

9.10 CHECKING THE TENSION OF THE BELT



Figure 9.10.1



Figure 9.10.2



Figure 9.10.3



Figure 9.10.4



Figure 9.10.5

Open the checking cover to reach the belt and tension device (Fig. 9.10.1). While tensioning check regularly tension. Push the belt down and with a pressure of 71N. This is approximately 7 kilograms or 15 pounds with this pressure the belt should move 3.5-4 mm or 1/8". It is recommended that the tensioning of the belt be measured with Optikrik II Device (Measuring range: 500-1400 N) (Fig. 9.10.2) The original pressure $P=1400$ N and after working a while it is $P=1100$ N.

ATTENTION:

NEVER "OVER" TENSION THE BELT, THE BELT WILL BE DESTROYED AND IT WILL NEVER RECOVER ITS ORIGINAL TENSION

Loose the contra nuts (Fig. 9.10.3), loose light the three bolts of the tension device (Fig. 9.10.4), and adjust the tension with the nut seen in (Fig. 9.10.5). When the right tension is reached: close the contra nuts and the three bolts of the support.

Reassemble in the same manner.

PLEASE MAKE SURE YOU CHECK THE TENSION OF THE BELT AFTER THE FIRST 15 HOURS OF OPERATION

9.11 REPLACING THE PULLEY UNITS

Take off engine as earlier described, dismount guard, frame and top cover as previous described.



Figure 9.11.1



Figure 9.11.2



Figure 9.11.3



Figure 9.11.4



Figure 9.11.5



Figure 9.11.6



Figure 9.11.7



Figure 9.11.8



Figure 9.11.9



Figure 9.11.10



Figure 9.11.11



Figure 9.11.12

Dismounting the driving pulley: take the top screw out to release the bushing (Fig.9.11.1), push the bushing together with the washer up (Fig.9.11.2), push washer down of the bushing (Fig.9.11.3), take bushing out (Fig.9.11.4), push key out (Fig.9.11.5), now the washer releases (Fig.9.11.6), dismount sealer cap (Fig.9.11.7)(Fig.9.11.8), the pulley can be released with two crowbars but do not use excessive force (Fig.9.11.9), push the sealer cap to dismount (Fig.9.11.10), by mounting back secure with sealant (Fig.9.11.11), center the holes to mount the pulley (Fig.9.11.12).



Figure 9.11.13



Figure 9.11.14



Figure 9.11.15

The two other pulleys: loose the five bolts of each pulley between the base plate and the motor base disc (Fig. 9.11.13). An oil seal ring (Fig. 9.11.14) and a seal (Fig. 9.11.15) should be placed on top of the pulley before mounting.

9.12 MOUNTING THE BELT

See here the schematic of the belt on the pulleys (Fig.9.12.1).

To dismount/mount the belt, follow the tensioning instruction in chapter: Checking the tension of the belt

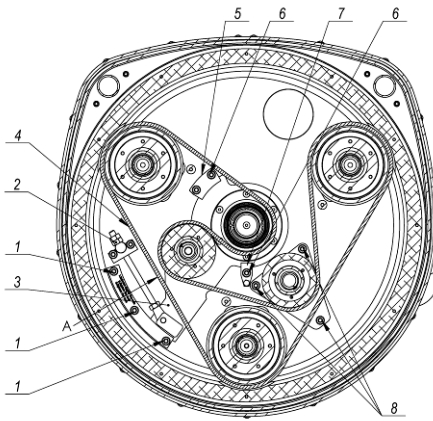

Figure 9.12.1

10. WARRANTY AND RETURNS

WARRANTY POLICY FOR THE LAVINA® S MACHINE

If your warranty card is missing, call your local distributor and request a warranty card or visit us at www.superabrasive.com to download one.

The customer is responsible for filling out the card and mailing it to the manufacturer's address indicated on the card. To ensure registration and activation of the warranty coverage, the warranty card must be mailed to the manufacturer within 30 days from date of purchase. Failure to mail the warranty card within 30 days from date of purchase may void the warranty. Make sure you provide the manufacturer with all the information requested, and most importantly with the distributor's name, machine serial number and purchase date

Superabrasive Inc. guarantees that the original purchaser of the machine will be covered against defects in material and workmanship for a period of 2 years from the date of delivery or 500 hours of use whichever comes first.

The following conditions pertain to this warranty:

Applies only to the original owner and it is not transferable.

Machine must not be dismantled and tampered with in any way.

Covered components proven defective will be repaired or replaced at no charge. Covered components include motors, bearings and switches.

This warranty does not apply to any repair arising from misuse, neglect or abuse, or to repair of proprietary parts.

This warranty does not apply to products with aftermarket alterations, changes, or modifications.

This warranty is in lieu of and excludes every condition of warranty not herein expressly set out and all liability for any form of consequential loss or damage is hereby expressly excluded.

This warranty is limited to repair or replacement of covered components and reasonable labor expenses.

All warranty returns must be shipped freight prepaid.

The above warranty conditions may be changed only by Superabrasive. Superabrasive reserves the right to inspect and make a final decision on any machine returned under this warranty. This warranty applies to new, used and demo machines.

Superabrasive does not authorize any person or representative to make any other warranty or to assume for us any liability in connection with the sale and operation of our products.

RETURN POLICY FOR LAVINA® S MACHINES

The Lavina® S machines may be returned, subject to the following terms:

In no case, a machine is to be returned to Superabrasive Inc. for credit or repair without prior authorization. Please contact Superabrasive Inc. or your local distributor for an authorization and issuance of a return authorization number. This number along with the serial number of the machine must be included on all packages and correspondence. Machines returned without prior authorization will remain property of the sender and Superabrasive Inc. will not be responsible for these.

No machines will be credited after 90 days from the date of invoice.

All returns must be shipped freight prepaid. All returns may be exchanged for other equipment or parts of equal dollar value. If machines are not exchanged, they are subject to a fifteen percent (15%) restocking fee.

11. DISPOSAL

If your machine after time is not usable or needs to be replaced, send the machine back to Superabrasive or a local distributor, where a professional disposal complying with the environment laws and directives is guaranteed.

12. MANUFACTURER'S CONTACTS

If you need to contact Superabrasive Inc. with technical support questions, below is the contact information.

Address: 9411 Jackson Trail Road, Hoshton GA 30548, USA

Email: info@superabrasive.us

Tel.: 706 658 1122

Fax: 706 658 0357

Website: www.superabrasive.com

13. SPARE PARTS

ASSEMBLY AND PARTS SPECIFICATIONS

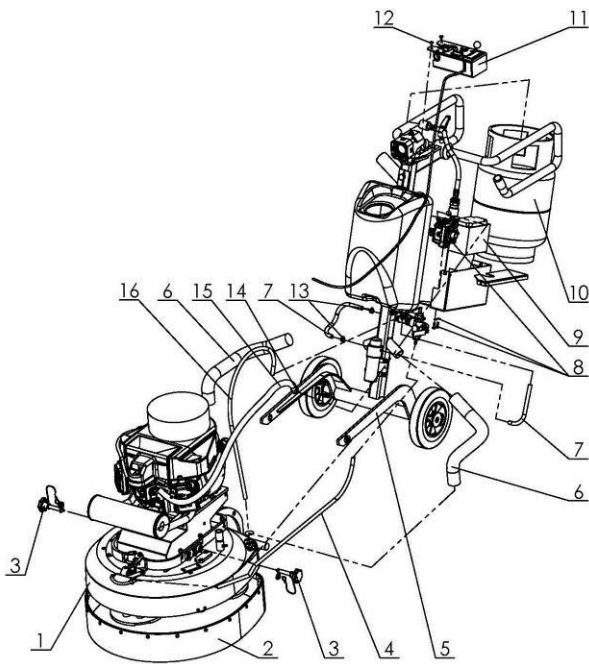

13.1 LAVINA® 25G-S GENERAL PARTS				
Model	No.	Item No.	Description	Pcs.
L25G-S	1	L25GS-10.00.00	Main Head	1
L25G-S	2	L25SPS-05.00.00.00	Guard Assembly	1
L25G-S	3	L25GS-03.00.00	Pin Assembly	2
L25G-S	4	MAR8.110	Tube	1
L25G-S	5	L25GS-20.00.00	Carriage With Control Box	1
L25G-S	6	D40L700	Vacuum Hose	2
L25G-S	7	MAR8.25	Tube	2
L25G-S	8	L25G-26.00.00	Regulator set	1
L25G-S	9	CC01-25968	12V Battery & Wire Connector	1
L25G-S	10	W2504	Propane Tank	1
L25G-S	11	L25GS-40.00.00	Control Board Ass.	1
L25G-S	12	M6X10ISO7380F	Screw	2
L25G-S	13	10-16DIN3017	Clamp	3
L25G-S	14	F0708750	Clamp	1
L25G-S	15	W2660	Tube	1
L25G-S	16	MAR8.84	Tube	1

13.2 LAVINA® 25G-S TOP COVER 1 PARTS

Model	No.	Item No.	Description	Pcs.
L25G-S	1	L25GS-19.00.00	Top Cover Assembly	1
L25G-S	2	M6X10ISO7380F	Screw	14
L25G-S	3	L25NSPS-07.00.00.05	Back Weight Holder	2
L25G-S	4	L25SPS-07.00.00.29	Rubber Buffer	3
L25G-S	5	L25GS-18.00.00	Frame Assembly	1
L25G-S	6	M8X20DIN6921	Bolt	8
L25G-S	7	L25GS-10.00.31	Pin	1
L25G-S	8	L25GS-15.00.03	Support Back	1
L25G-S	9	M10DIN982	Nut	1
L25G-S	10	L25NP-07.00.00.10	Cup	1
L25G-S	11	L25GS-15.00.04	Support Top	1
L25G-S	12	L25GS-15.00.02	Support Front	1
L25G-S	13	L25GS-10.00.30	Pin	1
L25G-S	14	L25GS-15.02.00	Bar	1
L25G-S	15	L25SPS-07.00.00.26	Stud	1
L25G-S	16	L25SPS-07.00.00.25	Spring	1
L25G-S	17	M5X12DIN6921	Bolt	2
L25G-S	18	A29.10.00	Spray Unit	1
L25G-S	19	L25G-10.00.69	Front Guard	1
L25G-S	20	L25S-15.00.23	Inspection Cover	1
L25G-S	21	L25GS-18.30.00	Clamp head	1

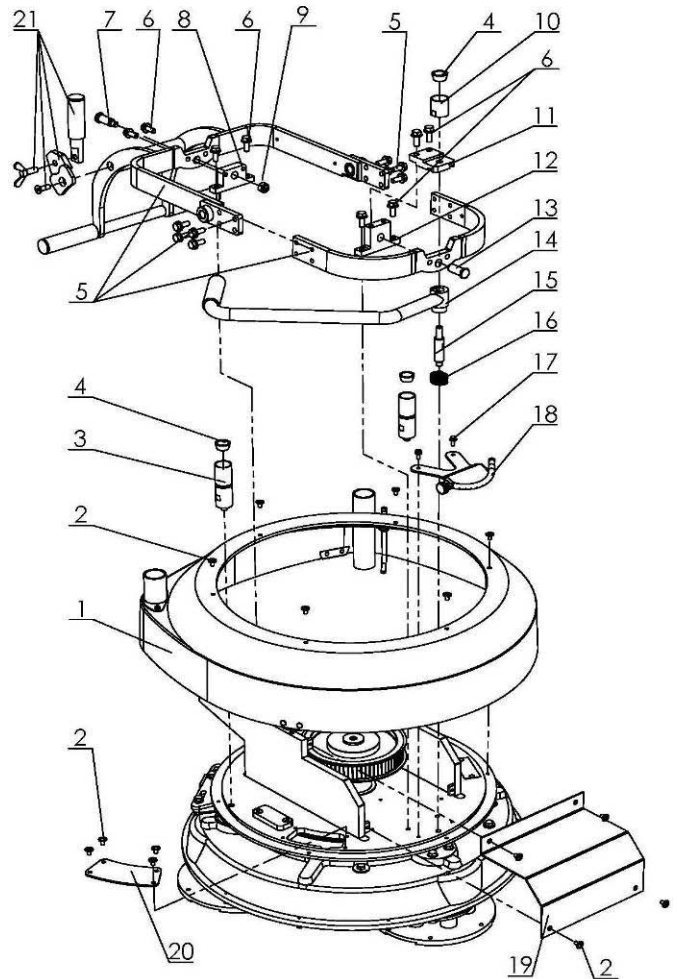

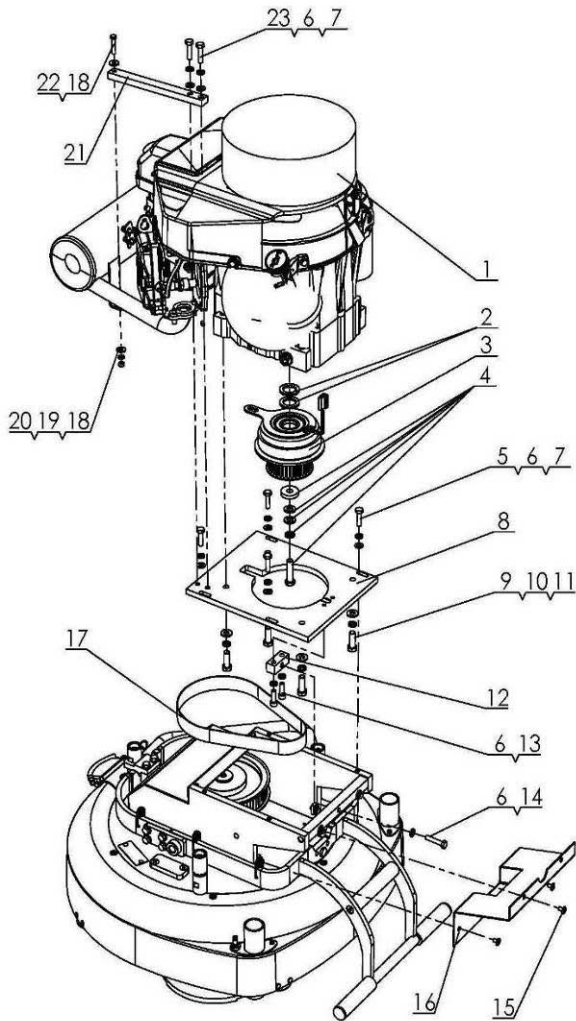

13.3 LAVINA® 25G-S ENGINE BASE PARTS

Model	No.	Item No.	Description	Pcs.
L25G-S	1	FS481VA-CS10-M	Kawasaki Engine	1
L25G-S	2	W1220	Clutch Washer	2
L25G-S	3	5215	Electric Clutch	1
L25G-S	4	L25G-10.02.02.S	Bolt Set	1
L25G-S	5	M8X25DIN933	Bolt	4
L25G-S	6	M8DIN127B	Spring Washer	9
L25G-S	7	M8DIN125A	Washer	6
L25G-S	8	L25G-10.00.65	Engine Base Plate	1
L25G-S	9	F33008	Washer	4
L25G-S	10	F33622	Washer	4
L25G-S	11	F13107	Bolt	4
L25G-S	12	L25G-10.00.66	Tensioning Device Support	1
L25G-S	13	M8X25DIN912	Screw	2
L25G-S	14	M8X40DIN933	Bolt	1
L25G-S	15	M6X10ISO7380F	Screw	4
L25G-S	16	L25G-10.05.00	Back Guard	1
L25G-S	17	OMEGAHP7608MHP30	Endless Transmission Belt	1
L25G-S	18	M6DIN9021A	Washer	2
L25G-S	19	M6DIN127B	Washer	1
L25G-S	20	M6DIN934	Nut	1
L25G-S	21	L25G-10.00.67-01	Support	1
L25G-S	22	M6X20DIN933	Bolt	1
L25G-S	23	M8X20DIN933	Bolt	2

13.4 LAVINA® 25G-S TOP COVER 2 PARTS

Model	No.	Item No.	Description	Pcs.
L25G-S	1	L25GS-19.00.01	Top Cover	1
L25G-S	2	L25GS-19.10.00	Vacuum Port	1
L25G-S	3	L25GS-19.20.00	Water Fitting	1
L25G-S	4	M12DIN985	Nut	1
L25G-S	5	M5DIN125A	Washer	4
L25G-S	6	M5DIN127B	Spring Washer	4
L25G-S	7	M5DIN934	Nut	4
L25G-S	8	L25SPS-04.01.00.00	Vacuum Port	1
L25G-S	9	M5X16DIN84A	Screw	3

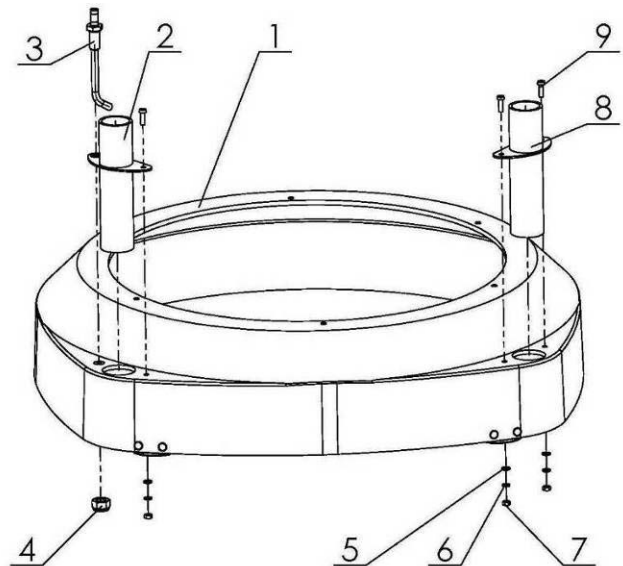

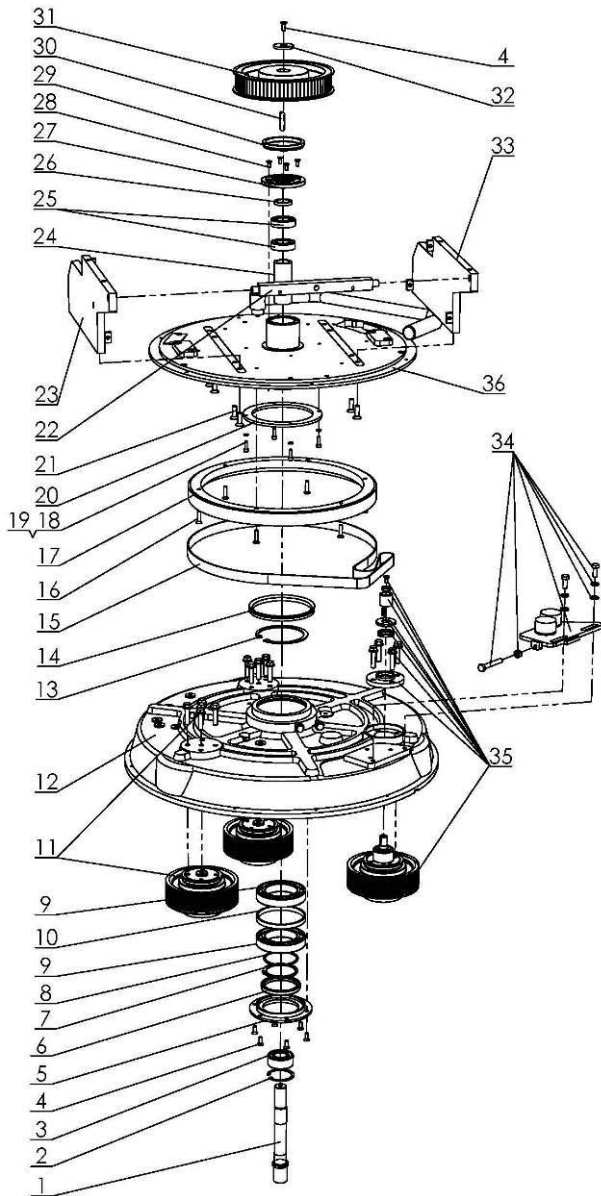

13.5 LAVINA® 25G-S PLANETARY DRIVE PARTS				
Model	No.	Item No.	Description	Pcs.
L25G-S	1	L25G-10.00.57	Shaft	1
L25G-S	2	A52DIN472	Retaining Ring	1
L25G-S	3	3205	Roller Assembly	1
L25G-S	4	M6X16DIN7991	Screw	7
L25G-S	5	L25L-10.00.21	Cap	1
L25G-S	6	TRA000650	Rotary Seal	1
L25G-S	7	B65DIN471	Retaining Ring	1
L25G-S	8	L25SPS-00.00.00.23	Compensating Ring	1
L25G-S	9	6013	Roller Assembly	2
L25G-S	10	L25SPS-00.00.00.34	Distance Ring	1
L25G-S	11	L25LS-11.00.00	Pulley Unit Assembly	2
L25G-S	12	L25LS-10.00.06	Disc	1
L25G-S	13	A10013943	Retaining Ring	1
L25G-S	14	TWVA01200	V-Ring Type A	1
L25G-S	15	TC-20EF1500X20X2	Endless Transmission Flat Belt	1
L25G-S	16	M6X25DIN7991	Screw	6
L25G-S	17	L25S-15.00.22	Planetary Pulley	1
L25G-S	18	M5DIN7980	Spring Washer	4
L25G-S	19	M5X16DIN912	Screw	4
L25G-S	20	L25P-01.03.00.09	Flange	1
L25G-S	21	M8X25DIN7991	Screw	8
L25G-S	22	L25G-10.00.64	Support Plate	1
L25G-S	23	L25GS-10.03.00	Left Plate Assembly	1
L25G-S	24	L25G-10.00.58	Bushing	1
L25G-S	25	6005	Roller Assembly	2
L25G-S	26	L25G-10.00.59	Insert	1
L25G-S	27	L25G-10.00.60	Cap for Rotary Seal	1
L25G-S	28	M5X12DIN7991	Screw	4
L25G-S	29	TWVA00700	V-Ring Type A	1
L25G-S	30	DIN6885A8X7X36	Key	1
L25G-S	31	L25G-10.00.61	Pulley Unit	1
L25G-S	32	L25SPS-00.00.00.15	Front Washer	1
L25G-S	33	L25GS-10.04.00	Right Plate Assembly	1
L25G-S	34	L25S-17.00.00	Planetary Tensioning Unit	1
L25G-S	35	L25LS-16.00.00	Driving Pulley Unit	1
L25G-S	36	L25GS-15.01.00	Base plate	1

13.6 LAVINA® 25G-S WATER SUPPLY PARTS

Model	No.	Item No.	Description	Pcs.
L25G-S	1	A29.21.00	Backflow Preventer	1
L25G-S	2	A29.22.00	Vent Valve	1

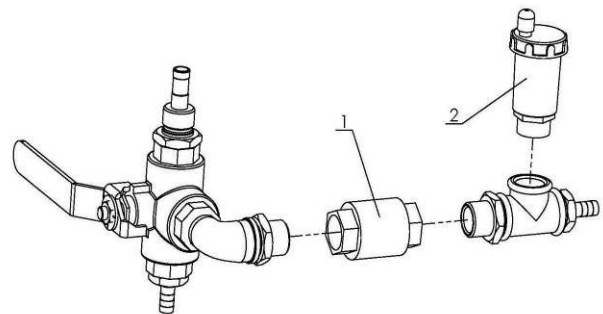

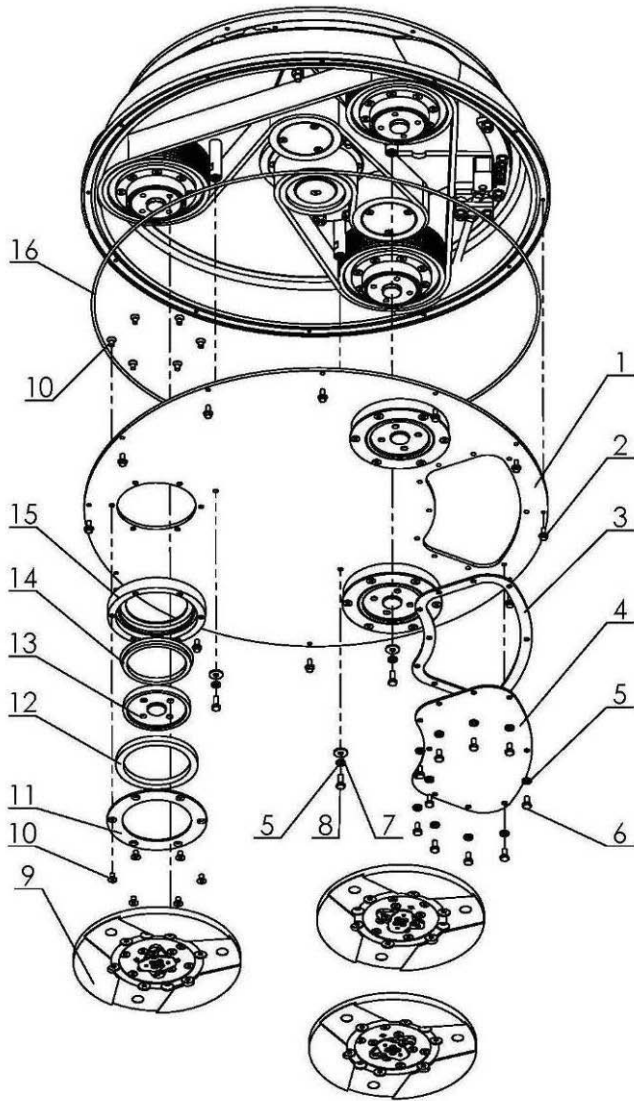

13.7 LAVINA® 25G-S BOTTOM COVER 1 PARTS

Model	No.	Item No.	Description	Pcs.
L25G-S	1	L25LS-14.00.00	Bottom Cover Assembly	1
L25G-S	2	M5X12DIN6921	Bolt	12
L25G-S	3	L25LS-14.00.05	Sealer Inspection Cover	1
L25G-S	4	L25L-10.00.09	Inspection Cover	1
L25G-S	5	M6DIN127B	Spring Washer	13
L25G-S	6	M6X12DIN933	Bolt	10
L25G-S	7	M6DIN9021	Washer	3
L25G-S	8	M6X16DIN933	Bolt	3
L25G-S	9	A31.00.00	Tool Holder A31	3
L25G-S	10	M6X10DIN7991	Screw	36
L25G-S	11	L25LS-14.00.03	Outer Cover	3
L25G-S	12	110X90X8.5	Felt Ring	3
L25G-S	13	A37.00.01	Adaptor	3
L25G-S	14	TWVA00800	V-Ring Type A	3
L25G-S	15	L25LS-14.00.02	Flange	3
L25G-S	16	D4X2X1880	Seal	1

13.8 LAVINA® 25G-S TOOL HOLDER PARTS

Model	No.	Item No.	Description	Pcs.
L25G-S	1	A31.10.00	Quick Change Assembly	1
L25G-S	2	M6X16DIN7991	Screw	4
L25G-S	3	M8X12DIN7991	Screw	12
L25G-S	4	A25.00.05-02	Spider	1
L25G-S	5	M8X25DIN7991-10.9	Screw	4
L25G-S	6	A25.00.10	Buffer	6
L25G-S	7	A31.20.00	Flange	1

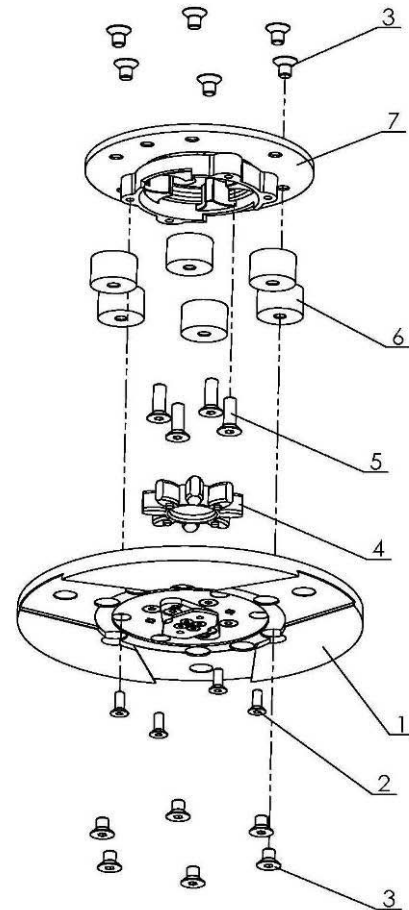

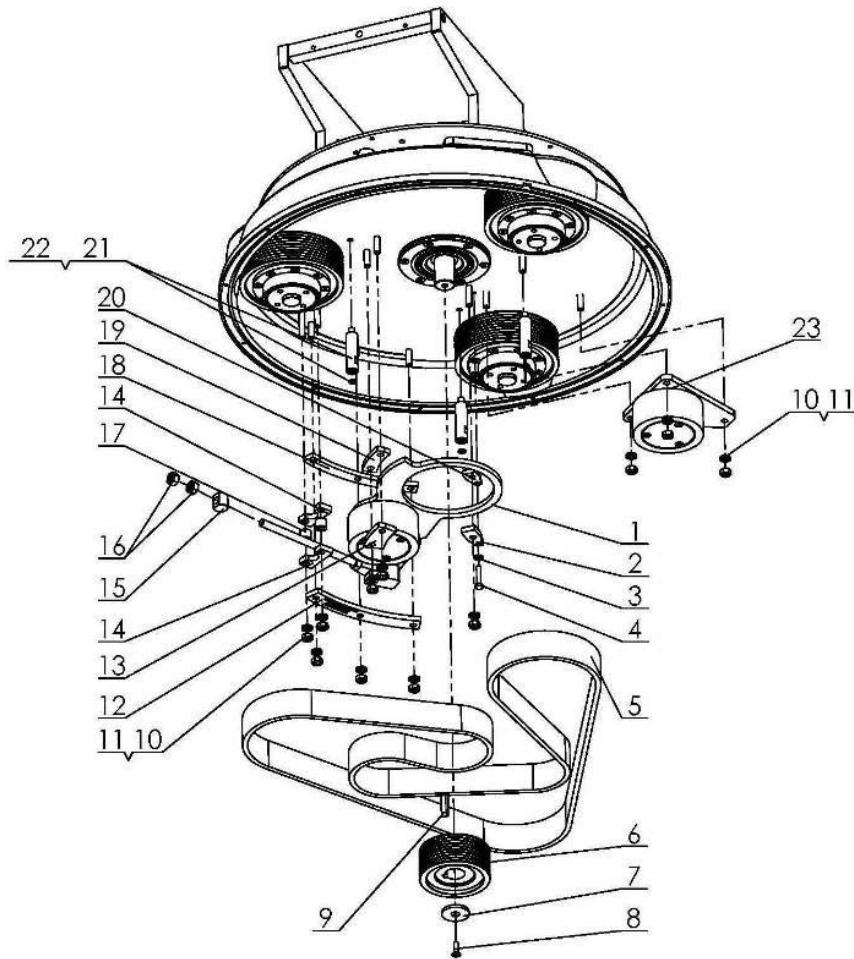

13.9 LAVINA® 25G-S BOTTOM COVER 2 PARTS

Model	No.	Item No.	Description	Pcs.	No.	Item No.	Description	Pcs.
L25G-S	1	L25L-12.00.00	Tensioning Support	1	13	L25L-10.00.12	Sector	1
L25G-S	2	L25L-10.00.16	Sector	1	14	L25L-10.00.07	Support	2
L25G-S	3	M6DIN127B	Spring Washer	1	15	L32C-14.20.04	Nut	1
L25G-S	4	M6X30DIN933	Bolt	1	16	M10DIN934	Nut	2
L25G-S	5	PL2476-975L-8	Endless Transmission V Belt	1	17	L25L-10.00.08	Washer	2
L25G-S	6	L25G-10.00.17	Central Pulley	1	18	L25L-10.00.13	Sector	1
L25G-S	7	L25SPS-00.00.00.15	Front Washer	1	19	L25L-10.00.11	Sector	1
L25G-S	8	M6X16DIN7991	Screw	1	20	L25L-10.00.15	Sector	1
L25G-S	9	DIN6885A8X7X36	Key	1	21	L25L-10.00.19	Distance Bolt	3
L25G-S	10	M8DIN127B	Spring Washer	11	22	D6X2	O-Ring	3
L25G-S	11	M8DIN934	Nut	11	23	L25L-13.00.00	Deflection Pulley	1
L25G-S	12	L25L-10.00.14	Sector	1				

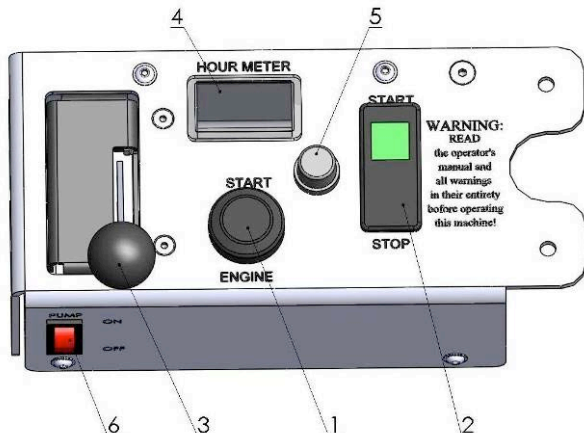

13.10 LAVINA® 25G-S CONTROL BOARD PARTS

Model	No.	Item No.	Description	Pcs.
L25G-S	1	W1301	Start/Stop Switch	1
L25G-S	2	W1330	Clutch Switch	1
L25G-S	3	W4110	Throttle	1
L25G-S	4	W4313	Hour Meter	1
L25G-S	5	6x30/30A	Fuse	1
L25G-S	6	W9999	Pump switch	1

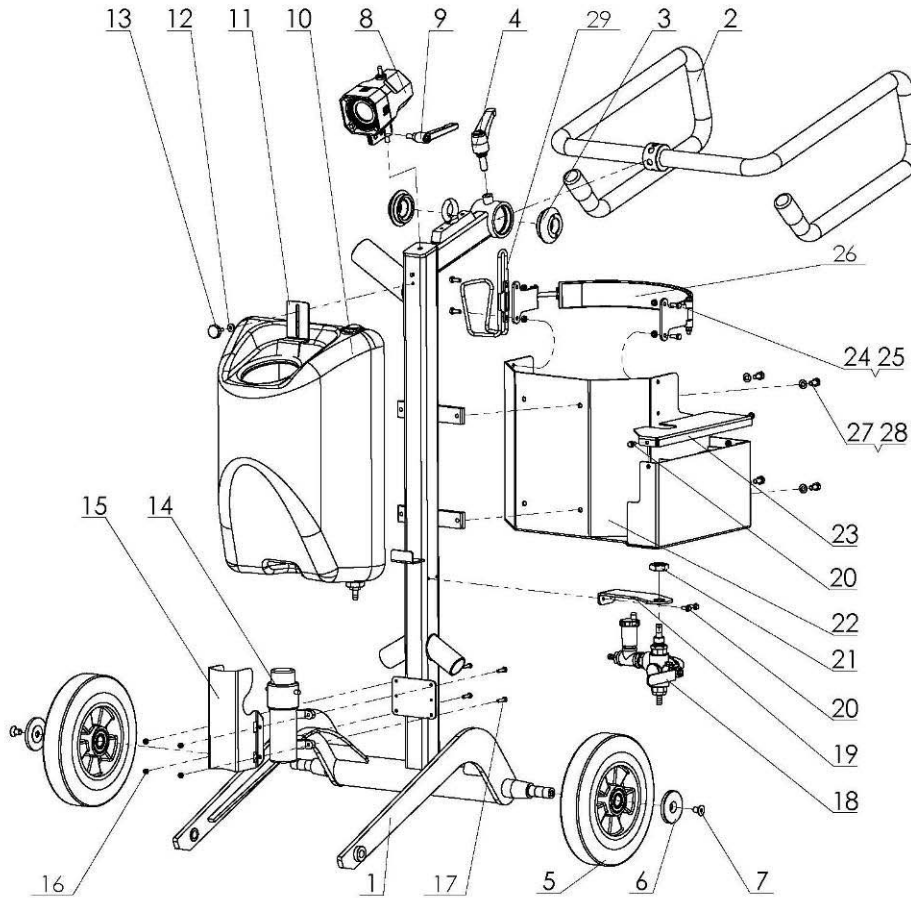

13.11 LAVINA® 25G-S CARRIAGE PARTS

Model	No.	Item No.	Description	Pcs.	No.	Item No.	Description	Pcs.
L25G-S	1	L25GS-21.00.00	Frame	1	16	M5DIN985	Nut	4
L25G-S	2	L25G-23.00.00	Handle Assembly	1	17	M5X20DIN933	Bolt	4
L25G-S	3	L25SPS-02.00.00.18-01	Nut	2	18	A29.20.00	Water Flow Control Unit	1
L25G-S	4	A58194	Swivel Bolt	1	19	A29.20.01-01	Flow Unit Base	1
L25G-S	5	L25G-20.00.04	Wheel	2	20	M5X12DIN6921	Bolt	4
L25G-S	6	L32D-20.00.03	Wheel Cap	2	21	M20X1.5DIN439B	Nut	1
L25G-S	7	M10X16DIN7991	Screw	2	22	L25G-22.00.00	Propane Tank Holder	1
L25G-S	8	L20NS-30.30.00	Lamp Unit Incl. Cable	1	23	L25G-20.00.05	Battery Cover	1
L25G-S	9	A58165	Swivel Bolt	1	24	M6X16DIN933	Bolt	4
L25G-S	10	A33.00.00	Tank	1	25	M6DIN985	Nut	4
L25G-S	11	L25P-02.00.00.01	Top Bracket	1	26	L25GS-25.00.00	Strap	1
L25G-S	12	M5UN732	Washer	1	27	M8DIN125A	Washer	4
L25G-S	13	T34391	Knob Bolt	1	28	M8X16DIN933	Bolt	4
L25G-S	14	1040	Water Pump	1	29		Cup Holder	1
L25G-S	15	L25S-20.00.26	Guard	1				

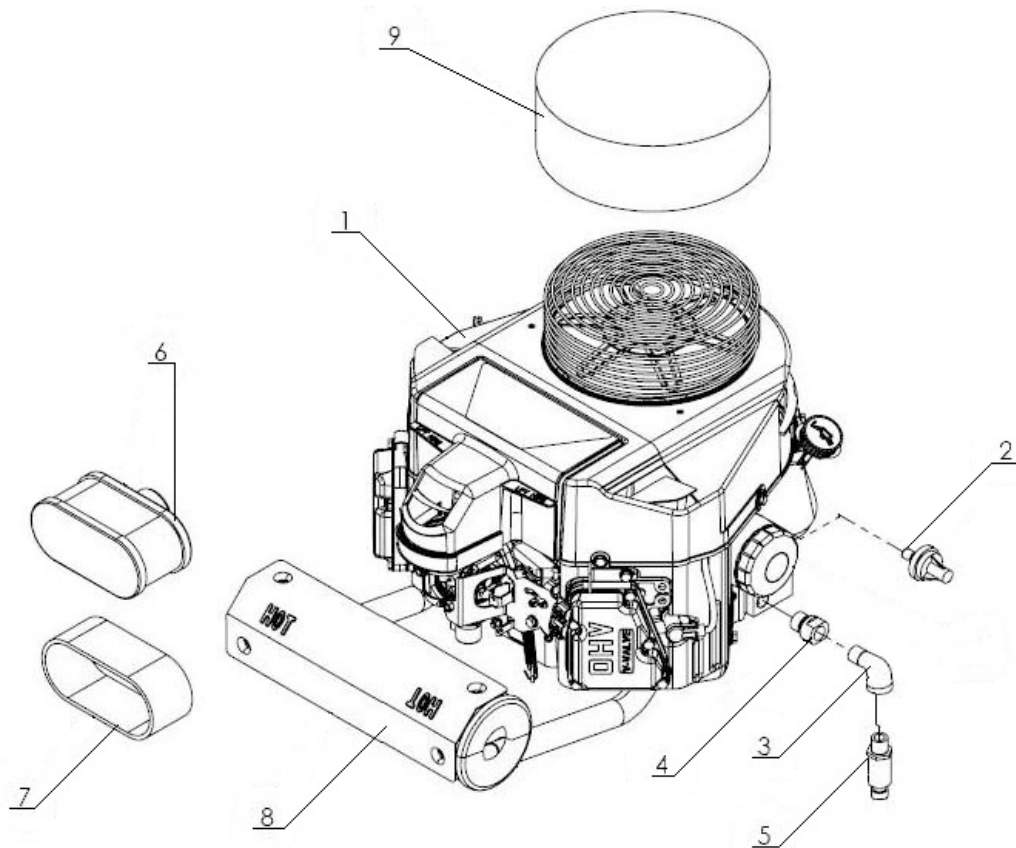

13.12 LAVINA® 25G-S ENGINE PARTS				
Model	No.	Item No.	Description	Pcs.
L25G-S	1	W3132	Kawasaki FS481V-AS10-M 18H 12V	1
L25G-S		K49065-7007	Oil Filter	12
L25G-S	2	W1325	Oil Pressure Switch	6
L25G-S	3	F466230	Elbow	1
L25G-S	4	K59071-7004	Joint	1
L25G-S	5	FE17409029909	Oil Drain Valve	1
L25G-S	6	K11013-7049	Element Air Filter	1
L25G-S	7	K11013-7046	Element Air Filter/ Fs481v (Foampre-Filter)	1
L25G-S	8	W3241A	Cat Muffler Assy.	1
L25G-S	9	W3305	Kawasaki Bonnet Filter	1